

A Process Model for Work-Flow Management in Construction

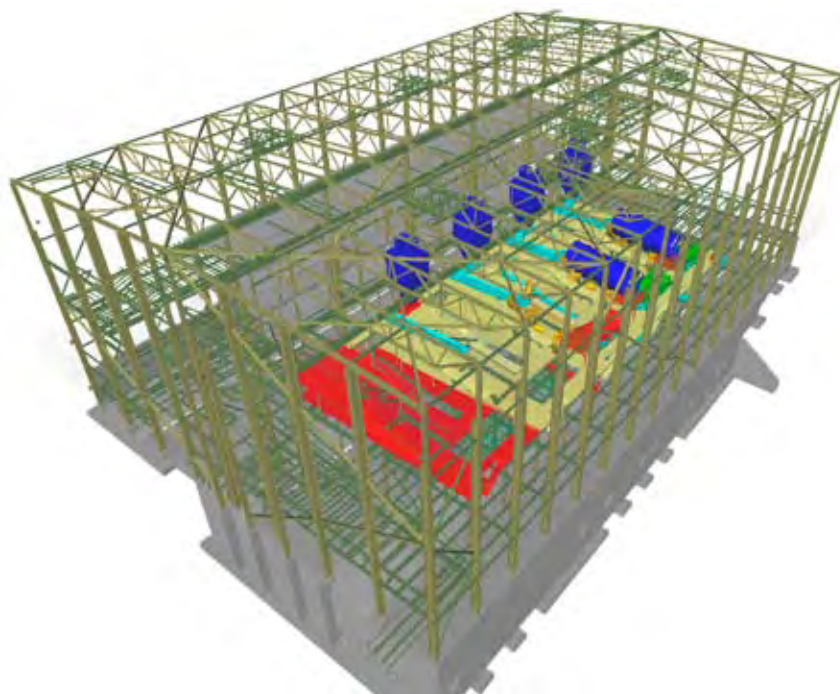

Rogier Jongeling

Luleå University of Technology
Department of Civil and Environmental Engineering
Division of Structural Engineering



DOCTORAL THESIS

A PROCESS MODEL FOR WORK-FLOW MANAGEMENT IN CONSTRUCTION

COMBINED USE OF LOCATION-BASED SCHEDULING AND 4D CAD

Rogier Jongeling

Luleå 2006

Division of Structural Engineering
Department of Civil and Environmental Engineering
Luleå University of Technology
SE - 971 87 LULEÅ
www.ltu.se/shb
construction.project.ltu.se

Preface

This PhD thesis is based on research carried out between 2003 and 2006 at the Division of Structural Engineering, the Department of Civil and Environmental Engineering at Luleå University of Technology. From March to July 2004 research was carried out at the Center for Integrated Facility Engineering (CIFE), Stanford University.

First of all, I would like to thank my supervisor Professor Thomas Olofsson for his continuous guidance and enthusiastic support of my work. I am also indebted to my advisor Professor Mats Emborg who provided me with many valuable suggestions for my research and for my life in Sweden. The two of you have given me great ideas and motivation to carry out the research and have made my work possible. I also would like to thank Professor Martin Fischer for giving me the possibility for an inspiring stay at CIFE and for undertaking the task as faculty opponent.

During my work as a PhD student I have met many interesting and friendly individuals that contributed greatly to the quality of my work and that made it a very enjoyable experience. I realize that mentioning a few will leave out many others, but I especially would like to thank Curt-Arne Carlsson, Thorbjörn Dorbell, Daniel Thall, Anders Pettersson, Jan-Olof Edgar, Martin Asp, Johan Appelqvist, Håkan Norberg, and again Thomas Olofsson and Mats Emborg for being such great and helpful people.

I have gained many insights from working with construction experts during my case studies of construction projects. The companies Betongindustri, Ceco, Enterprixe, JM and NCC are acknowledged for generously allocating time and

resources. I also appreciate the contributions of the staff at the Division of Structural Engineering in Luleå and by my research colleagues at CIFE.

The financial support has been provided by The Development Fund of the Swedish Construction Industry (SBUF), Lars Erik Lundbergs Stiftelse, Knut & Alice Wallenberg Stiftelse and The Swedish Research Council for Environment, Agricultural Sciences and Spatial Planning (Formas).

I am grateful to my family and friends in Holland and Sweden for their support and for encouraging me to do what I do and to be who I am. Helma, Tjeerd, Leonie, Sander and Marijn thank you for always being there for me.

Finally, Helena my wonderful wife, thank you for always supporting me and for all your sacrifices during my studies. You are truly the most important part of my life!

Luleå, October 2006

Rogier Jongeling

Abstract

This thesis describes a novel approach for management of work-flow in construction, based on the combination of location-based scheduling and simulations with 4D CAD.

Construction planners need to carefully design a process that ensures a continuous and reliable flow of resources through different locations in a project. The flow of resources through locations, termed work-flow, and the resultant ability to control the hand-over between both locations and crews, greatly empowers the management of construction operations. Today's scheduling practice for construction work shows that planning for work-flow is deficient due to practical and methodological reasons. Focus is mainly placed on planning of transformations and flow management is not explicitly addressed, but is rather being realized as a side-product of short-term task management. In addition, today's scheduling techniques provide limited insight in the spatial configuration of construction operations, thereby limiting the communication among project stakeholders and, as a result, limiting the planning and control of work-flow.

I present a novel process model for the management of work-flow in construction, which provides project stakeholders with spatial insight in the flow of construction work. The model is based on a combination of two concepts: Lean Construction and Virtual Design and Construction. The suggested process model provides mechanisms for two levels of work-flow management: macro- and micro-management. Scheduling of work-flow on a macro-level is based on a combination of location-based scheduling and 4D CAD and is suggested as an alternative to today's common discipline-oriented work breakdown scheduling approach. This level of work-flow management is

best initiated in early stages of a project and aims to provide insight in the overall flow of work on a construction site. The micro-management of work-flow is intended to be an instrument in the planning and control of day-to-day construction tasks. Based on the macro-management work-flow plan, more detailed look-a-head schedules can be constructed for the purpose of micro-management where necessary prerequisites for efficient and safe execution of construction tasks can be controlled, using a space-based 4D model.

Five test cases have been used to develop, apply and validate my suggested process model:

- The first test case is of an explorative character and provides theoretical and practical insights in the application of Virtual Design and Construction techniques.
- The second case is based on Test Case I and explores modelling with 4D CAD in further detail. Test Case II suggests that data extracted from 4D models can be used in planning and analyses of construction work.
- Based on theoretical studies of Lean Construction and Virtual Design and Construction and results from the first two test cases I developed a process model for planning of work-flow management. The applicability of the process model is validated in the third test case.
- The fourth test case presents an application and validation of the suggested process model for work-flow management.
- Finally, the fifth test case extends and applies the developed method from Test Case III and results in a formal process description for the management of work-flow in construction.

Application of the proposed process model in the test cases shows that the combined use of location-based scheduling and 4D CAD is a suitable method to plan and control work-flow. The location-based scheduling technique allows planners to gain insight in the flow of resources through locations in projects. The 4D CAD model is a valuable supplement to the location-based schedule and allows users to quickly and clearly gain insight in the spatial configuration of construction work.

I believe that this and other combinations of Virtual Design and Construction methods with principles from Lean Construction can contribute significantly to the value of the end product and the reduction of waste in the construction process.

Key words: Work-Flow, Location-based Scheduling, 4D CAD, Virtual Design and Construction, Lean Construction

Abbreviations

3D CAD	Three-dimensional Computer Aided Design
4D CAD	3D CAD integrated with schedule data (time)
ABC	Activity-Based Costing
ADT	Architectural DeskTop
AEC	Architecture, Engineering and Construction
BIM	Building Information Model
BoM	Bill of Materials
CAD	Computer Aided Design
CAM	Computer Aided Manufacturing
CIFE	Center for Integrated Facility Engineering
CPM	Critical Path Method
DWG	Drawing file developed and used by Autodesk Inc.
GPM	Geometry-based Process Method
HVAC	Heating Ventilation Air-Conditioning

IAI	International Alliance for Interoperability
ICT	Information and Communication Technology
IFC	Industry Foundation Classes
IT	Information Technology
KPI	Key Performance Indicators
LBS	Location Breakdown Structure
LCI	Lean Construction Institute
LoB	Line-of-Balance
nD	n-Dimensional, in which n is a number
PE	Project Explorer
PIO	Project Information Officer
PPC	Percent Plan Complete
SBUF	Svenska Byggbranschens UtvecklingsFond. Development Fund of the Swedish Construction Industry.
SCC	Self-Compacting Concrete
SCM	Supply Chain Management
TFV	Transformation Flow Value
VBE	Virtual Building Environment
VDC	Virtual Design and Construction
VRML	Virtual Reality Mark up Language
WBS	Work Breakdown Structure
XML	eXtensible Mark up Language

Table of Contents

PREFACE	III
ABSTRACT.....	V
ABBREVIATIONS	VII
TABLE OF CONTENTS	IX
1 INTRODUCTION	1
1.1 Background	1
1.2 Aim and scope.....	4
1.3 Research questions	4
1.4 Definitions.....	5
1.5 Limitations	7
1.6 Research approach	7
1.7 Thesis outline	10
2 THEORY	13
2.1 Virtual Design and Construction.....	13
2.2 Product modelling	17
2.3 Project planning	19
2.4 Lean Construction	28
2.5 Work-flow management.....	30
2.6 Production simulation	33
3 RESULTS FROM THE TEST CASES	35
3.1 Test Case I – nD modelling.....	35
3.2 Test Case II – Quantitative analyses using 4D models	38
3.3 Test Case III – Location-based scheduling and 4D CAD	40

3.4	Test Case IV – Work-space-based 4D models	43
3.5	Test Case V – Macro- and micro-management of work-flow	45
3.6	Summary of test case results	48
4	CONCLUSIONS, VALIDATION AND DISCUSSIONS.....	49
4.1	Scientific contribution.....	50
4.2	Practical contribution	51
4.3	Validation and generalization	52
4.4	Discussions	53
4.5	Suggestions for further research	55
	REFERENCES	57
	PUBLICATIONS.....	63
	Appended papers	63
	Conference articles	64
	Articles and Reports	65

1 INTRODUCTION

1.1 Background

Comparisons of the construction industry with the manufacturing industry show remarkable differences in efficiency, organization and applied technology in the production process (SOU 2000). What is more remarkable is that these differences have been known for so long and that the gap is widening.

It is often argued that one cannot compare building houses with manufacturing cars. Every building is unique and made according to the customers' requirements. It is true that a car model is developed once and then manufactured in a serial production unit within the controlled environment of a factory. However, this does not mean that all cars are identical. Scania for example, a large manufacturer of heavy vehicles, produces custom-made vehicles out of a limit set of standardized components (Scania 2006). There are a number of factors that facilitate this manufacturing process, such as the project environment, the product development process and the use of ICT (Andersson 2006; Toolanen 2006).

The simultaneous product development process, as introduced by the Japanese car industry, changed the traditional sequential development process into integrated concurrent engineering processes. In a benchmarking study of major automotive manufacturers this technique did not only prove to be faster, but the simultaneous design process appeared to require less engineering hours and results in products better adapted to the production process, which in turn results in better quality of the end product (Womack 1990). This method of

product development is part of a manufacturing philosophy referred to as Lean Production.

The development and application of IT applications has also been a key to the introduction of new and faster product development and manufacturing methods. During the 1970s, the product design phase was followed by testing of physical prototypes. The introduction of Computer Aided Design (CAD) and Computer Aided Manufacturing (CAM) systems in the 1980s increased the speed of the design and documentation work, but did not radically change the development process. New IT tools have emerged, with the introduction of a simultaneous development process, that allow users to simulate, analyse and optimize digital prototypes. Today, a product can be designed, tested and validated before the first physical prototype is built. Multiple design solutions can be evaluated in a computer, which leads to a faster design process and a more optimized end product. I refer to this practice as Virtual Prototyping.

The manufacturing industry has radically changed over the past century, with a transition from craft production via mass production to Lean Production. But what happened in the construction industry? This industry has also seen its transitions, although not as radical as in manufacturing. A number of specialized niches in construction show similarities with the manufacturing industry. NCC, a Swedish construction company, launched a residential building concept in spring 2006 where 90% of all components are preassembled in factories, using among other things CAD-CAM technology. The building components are subsequently assembled on site, by craftsmen wearing white gloves, in half of the time compared to traditional construction according to NCC (NCC 2006). It may appear that things have changed in construction. However, the gross volume of construction is still concerned with outdoor assembly processes on a construction site, where different organisations plan and execute their work using document-based information, produced by functional-oriented organisations.

Many reports have been written about the shortcomings of the construction industry (Koskela 1992; SOU 2002). A recent in-depth study of seven Swedish construction projects reveals that a construction worker spends only 15-20% of the time on direct work (Josephson 2005). According to the study, approximately 45% is spent on indirect work (preparations, instructions, getting material, etc.) and the remaining 35% is spent on redoing errors, waiting, disruptions, etc. One can conclude that there is room for improvement.

This research is not about a comparison of the manufacturing industry with the construction industry, but rather adapts concepts that mainly originate from manufacturing in order to improve the execution of work on a construction site. I have been especially inspired by two concepts: Lean Production and Virtual Prototyping. These concepts start to be adapted by the construction industry and are commonly referred to as Lean Construction and Virtual Design and Construction.

Lean Construction is to a great extent an adaptation and implementation of Japanese manufacturing principles within the construction process. Even though the guiding principles were not formulated until after nearly ten years of research and application, one may deduce that from the beginning they were: While delivering the project, maximize the value for the client and minimize the waste (Bertelsen 2004). The introduction of the concept of flow is probably the most important contribution to the understanding of the construction process made by the Lean Construction research community (Bertelsen 2004).

Virtual Design and Construction is defined as the use of multi-disciplinary performance models of design-construction projects, including the product (i.e. facilities), organization of the design-construction-operation team, and work processes, to support explicit and public business objectives (Fischer 2004b). That is, one would like to analyse, simulate and predict the quality of the end product (e.g. a building) and the characteristics of the process to build and operate the product. Both the product and the processes must be virtually designed and simulated, before construction commences, in order to be able to truly evaluate different design and construction alternatives against project objectives.

I believe that one of the keys to improving the execution of construction work is improving the flow of work, i.e. the movement of tasks through a work process. Today's scheduling practice for construction work shows us that planning for work-flow is deficient due to practical and methodological reasons. The customary approach is to prepare a master schedule that is used as a basis for more detailed plans. The master schedule often becomes obsolete, due to the lack of updates during construction work. As a result, the schedule loses its value as an instrument to plan and control construction work. Focus is placed on planning transformations and flow management is not explicitly addressed, but is rather being realized as a side-product of short-term task management (Koskela 2002). Another difficulty related to today's scheduling practice stems from the use of 2D drawings. Schedules alone do not provide

with enough information about the spatial configuration of a project. To identify spatial aspects of a project, users must look at 2D drawings to conceptually associate the building components with the related activities from a schedule. This practice makes effective communication among project participants difficult and limits the planning and control of work-flow.

A Virtual Design and Construction method that combines planning data and spatial data in one environment is 4D CAD. 4D modelling is a process model in which 3D CAD models are visualized in a 4-dimensional environment and allows project stakeholders to simulate and analyze what-if scenarios before commencing work execution on site. Planning supported by visual analyses of 4D CAD models is considered more useful and better than traditional planning (Fischer 2004c; Heesom 2004). However, I found in my early research work that today's 4D CAD models do not provide sufficient insight in the flow of work in a construction project, but I also realized that 4D CAD has the potential to provide this insight. This understanding, or Big Idea, is the basis for my research.

1.2 Aim and scope

The aim of this research is to define a process model for the management of work-flow in construction based on a combination of Virtual Design and Construction methods with concepts from Lean Construction. More specifically, the scope of the research is to combine 4D CAD technology, which is a specific Virtual Design and Construction method, with the concept of flow that follows from Lean Construction research.

The research aims to provide a model that can be practically applied to different types of projects in the construction industry. The model should be based on a combination of theory and empirical findings from practical experiments.

1.3 Research questions

The research addresses three research questions where the first research question is related to project planning and more specifically to management of work-flow. The second question concerns Virtual Design and Construction methods and also focuses on the management of work-flow and the third question aims to combine the concepts from the first two questions.

Research question I

What is the practice today to plan and manage the flow of construction work?

This question is aimed at providing insight in today's common practice for project planning in construction. The question also considers Lean Construction since this is an emerging area of research and practical application that explicitly addresses the concept of flow.

Research question II

What is Virtual Design & Construction and how can it support the management of the flow of construction work?

Research question II provides a deeper understanding of Virtual Design and Construction methods and more specifically of 4D CAD. 4D CAD is also considered from the perspective of modelling, simulation and analyses of the flow of construction work.

Research question III

How can a Virtual Design and Construction-based process model be constructed to support work-flow management of construction work?

The third question is an integration of question I and II, since these research questions are strongly interrelated; the process model for work-flow management should be designed to take advantage of virtual modelling techniques, and the modelling techniques should support the management of work-flow.

The answer to research question III will provide an understanding and a method that combines management of work-flow and Virtual Design and Construction techniques. The proposed process model for work-flow management should be based on a solid theoretical framework supported by empirical findings from test cases.

1.4 Definitions

There are a number of terms and definitions that I refer to throughout this thesis that require explanation to provide understanding of the scope of research and research results.

Project planning

The first research question concentrates on project planning. I refer to project planning as the planning and control of construction activities, including the choice of construction methods, the definition of tasks, the estimation of required resources and the identification and coordination of any interactions among different tasks and use of common resources. Project planning is part of construction management, which is a broader term that includes all activities required in the total construction process from the conceptual development stage, through design, to hand-over to the client.

Activities and tasks

Throughout this thesis, including the appended papers, I refer to planning, scheduling, management and control of construction tasks and activities. The terms task and activity have formally different meanings. According to Clough (2000) an activity defines a part of project that needs to be accomplished and a task is a part of a project that needs to be accomplished within a defined period of time. However, I use both terms to denote one and the same concept: a discrete construction operation, with or without a specification for the start time, duration, resources and locations.

Planning and scheduling

The same applies to planning and scheduling of construction operations. Planning literally means the creation of a plan, in which a plan is a proposed method of getting from one set of circumstances to another. Scheduling concerns the allocation of resources to tasks over time (Hendrickson 2000). Planning is a broader term than scheduling, but both terms are used in this thesis to refer to the same concept: a proposed method of getting construction work done, including the definition of construction operations.

Management and control

Management and control of construction operations are in fact two different concepts in which control often is seen as one of the roles of management. When referring to management or control of construction operations the process of looking ahead is considered. Being in control of construction work is that point in time for which one can plan preconditions for the execution of construction operations with sufficient reliability (Ballard 2006).

Virtual Design and Construction

The second research question refers to Virtual Design and Construction techniques. The terms product modelling and Building Information Models (BIM) are also used in conjunction with Virtual Design and Construction techniques, but are examples of specific techniques and are not synonym to Virtual Design and Construction.

1.5 Limitations

The process model that results from the third research question is mostly based on cases from Swedish construction projects. However, the basic components of the process model should be applicable to any construction project. To limit the scope, I have not considered the costs of construction operations and I have focused on the planning and control of work-locations for tasks on a construction site. I have not considered the relation between locations and neither the allocation of a location for multiple concurrent uses.

1.6 Research approach

The main steps for my PhD research have been defining the aim of the research and research questions, followed by theoretical studies, prototype development and 4D modelling. These components were subsequently applied in test cases which resulted in a basis for further research and for validations. Overall, I followed five main cycles of these steps during my research, of which each cycle contained a test case. Chapter 3 describes the test cases in further detail and presents the results of the cases. I choose to use test cases, based on construction industry projects, to conduct my research work. The test cases enabled me to identify and limit my research topic and allowed me to focus on different research components and relations between these components, including the people working with or relevant to these components.

Holme, et al. (1996) identify three different, but overlapping, research approaches (Holme 1996): the analytical approach, the systems approach and the actors approach. In the analytical approach a studied object is divided into parts which are independently analysed and subsequently re-assembled to form a complete picture. The approach aims to find explanations and hard facts for the problems that are studied, using mostly logic and mathematics.

The systems approach relies on the notion that components interact with each other and are therefore studied in a complex environment, where the whole is

prioritized. Components are described in their contexts in which the researcher interacts with the environment of the components and with the people involved. A picture of the system is subsequently developed and the components and their relations can be described and understood.

In the actors approach the focus is the deep understanding of social situations and human consciousness from the view of individual participants. There is no interest in explanations, rather in an understanding of the holistic expression of the present problems and phenomena.

I have adapted a systems approach with analytical aspects to conduct my research. The design, planning and construction processes are complex and interrelated. The nature of my research components required me to approach the research in a way that enabled focus on both the components and the relations between these components. In my research I have, to a limited degree, attempted to adapt an analytical approach as well in an effort to explain and prove my research problem and research outcome. Although the adaptation and results of this analytical approach are limited I do believe that these analytical aspects add to the overall understanding of the research problem and contribute to the validation of the research outcome.

During the phases of my PhD research I have forced myself to approach my research from different perspectives by taking on different roles. This qualitative research approach allowed me to actively gain a broad insight in my research topic and provided me with understanding of the different components of my research including the relations between these components.

First of all I have studied literature and documentation relevant to my research topic. Secondly I have been an observer in projects where I gathered data throughout interviews, attending project meetings, studying project documentation and by observing the execution of work on the construction site. These interviews varied from open un-structured interviews to more structured interviews with prepared questions and fixed answers. Thirdly I have been actively participating in construction projects, creating different types of 3D and 4D models. Taking this role has been a time-consuming, but valuable experience, since I had a chance to work with data and stakeholders from industry projects in which I developed and applied my own research ideas. My fourth role has been a system developer. Although I have not written a single line of computer software code, I have been actively involved in the specification, development and testing of prototype software systems for project planning- and 4D modelling purposes. My fifth and final role has been

a teacher and presenter of my research work to others. Especially this fifth role has forced me to constantly and clearly define my work and results during my PhD research.

Two main areas of research, Virtual Design and Construction and Lean Construction, provided me with knowledge and inspiration for my research work. They guided me in formulating research aims as well as in the definition, exploration and validation of the proposed process model for work-flow management using five industry test cases:

- The first test case, the ITstomme project, provided me with technical insight in and practical experience of Virtual Design and Construction techniques, and gave me my first hands-on experience of 4D CAD.
- Test Case II provided me with a deeper insight in the opportunities of 4D modelling and the limitations of today's 4D modelling practice. Also, at this stage the importance of managing the flow of work through locations in construction projects became clear.
- In the third test case I studied location-based scheduling techniques as an alternative scheduling method to activity-based scheduling for 4D modelling. I formalized a method for combined use of location-based scheduling and 4D CAD and introduced the method in a graduate course on virtual construction. The feedback from participating PhD students and experts from the industry provided me with valuable insights.
- I applied the developed method in Test Case IV to a multi-storey timber housing project to validate and further explore the possibilities of analysing the work-flow on the construction site. Part of this test case was a theoretical study of Lean Construction in order to link lean principals to the proposed process model for work-flow management.
- The final test case gave me the opportunity to validate and refine the proposed process model in a large construction project. I studied and developed different approaches for scheduling and visualisation of complex work-flow patterns and use of work-spaces, which I discussed with project planners to further explore the possibilities of the proposed method.

1.7 Thesis outline

Chapter 1 introduces the research, including the overall aim, the research questions and the research method.

Chapter 2 describes the theory behind the main concepts of this research and related work.

Chapter 3 presents and discusses the test cases used in the definition, testing and validation of the different approaches to process modelling of work-flow management.

Chapter 4 includes a summary of the research contributions, validations, discussions and recommendation for future work.

The contents of this thesis are based on five appended papers. Each paper corresponds with a test case (Chapter 3):

Paper I

Jongeling R, Emborg M and Olofsson T (2005) “nD modelling in the development of cast in place concrete structures”, *ITcon Vol. 10, Special Issue From 3D to nD modelling*, 27-41, <http://www.itcon.org/2005/4>

Paper I presents the results of the development and application of different model dimensions in practice. The main motivation to conduct this study was to use product models beyond their common, but limited, use in 3D. The paper reports my first theoretical and practical insights in the use of 4D modelling and provides a basis for research work that is reported in Paper II-V. I wrote this paper together with Professor Mats Emborg and Professor Thomas Olofsson, who reviewed and supervised the work.

Paper II

Jongeling, R., Kim, J., Mourgues, C., Fischer, M., Olofsson T. (2006) “Quantitative Analyses Using 4D Models - An Explorative Study”, *Submitted to Automation in Construction, Special Issue on Digital Construction (September 2006)*

Paper II illustrates how to analyze, compare and present 4D content quantitatively. I conducted this study together with my fellow researchers at Stanford University, CIFE, during spring 2004. My main contributions to this

paper are the idea and method to extract, present and analyze 4D content quantitatively. Jonghoon Kim contributed to the research by analyzing temporary structure planning based on 4D content and Claudio Mourgues analyzed the relation between quantitative 4D data and costs of construction operations. Professor Martin Fischer and Professor Thomas Olofsson have reviewed the work. I presented a condensed version of this paper at the ICCEM 2005 conference:

Jongeling, R., Kim, J., Mourgues, C., Fischer, M., Olofsson T. (2005) "Quantitative Analysis Using 4D Models - An Explorative Study." In C. Park (eds) *First International Conference on Construction Engineering and Management*, Seoul, Korea.

Paper III

Jongeling, R., Olofsson, T. (2006) "A method for planning of work-flow by combined use of location-based scheduling and 4D CAD." *Automation in Construction (article in press)*

In Paper III I present the concept of work-flow and consider location-based 4D modelling as an alternative to activity-based 4D modelling. Paper III also presents a process model for the combined use of location-based scheduling and 4D CAD. I wrote this paper together with Professor Thomas Olofsson, who reviewed the research work and assisted in defining the process model.

Paper IV

Björnfot, A., Jongeling, R. (2006) "Application of Line-of-Balance and 4D CAD for Lean Planning." *Accepted for publication in Construction Innovation (July 2006)*

After having defined a process model in Paper III for planning of construction operations with the Line-of-Balance scheduling technique in combination with 4D CAD, I applied the method to a multi-storey timber housing project in Sweden. I conducted this study together with Anders Björnfot at Luleå University of Technology, who provided me with valuable insights in Lean Construction and timber construction processes. My main contribution to this paper is the application of a process model for the combined use of 4D CAD and scheduling with the Line-of-Balance technique.

Paper V

Jongeling, R., Olofsson, T. (2006). "A method for macro- and micro-management of work-flow by combined use of location-based scheduling and 4D CAD." *Submitted to Computer-Aided Civil and Infrastructure Engineering (March 2006)*

Paper V presents the final test case of my research in which I extend and apply the process model from Paper III. Based on insights from mainly Test Case III and IV I consider work-flow of construction work in this paper on two levels: a macro- and a micro-level. I wrote this paper together with Thomas Olofsson, who reviewed the work.

2 THEORY

This chapter introduces the main theoretical framework on which this research is based. 4D CAD is a specific Virtual Design and Construction technique and relies on project planning methods.

2.1 Virtual Design and Construction

The Virtual Design and Construction process, as defined in the Chapter 1, aims to analyse, simulate and predict the quality of the end product (e.g. a building) and the characteristics of the process to build and operate the product. Both the product and the processes must be virtually designed and simulated, before construction commences, in order to be able to truly evaluate different design and construction alternatives against project objectives. The Virtual Design and Construction process heavily relies on the use of CAD and other IT systems, but is not limited to these tools. The organization of the process is as important as the applied technology in the process.

Most of today's construction projects are structured according to a sequential product development process in which each activity is separated in time and space, Figure 2.1. The process is often slow and reflects functional oriented organizations, leading to deficient communication and conflicts between the different functional teams in the design and production relay-race.

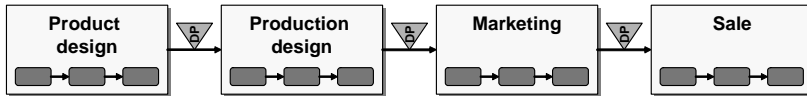

Figure 2.1: *Sequential development process commonly applied in today's construction process (DP = decision point)*

Applying the Virtual Design and Construction methods implies not only a change of IT-tools, but also requires a change of processes. The use of Virtual Design and Construction methods can benefit the sequential product development process, but the true benefits of the technology lay in a simultaneous product development process, Figure 2.2.

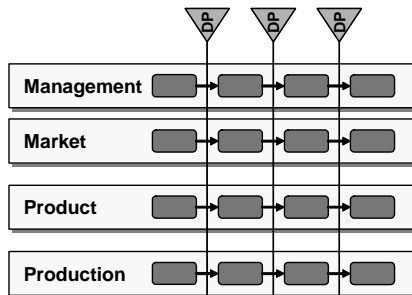

Figure 2.2: *Simultaneous product development process is suggested as an alternative to today's sequential development process (DP = decision point)*

The simultaneous product development process, as introduced by the Japanese car industry, changed the traditional sequential product development process into integrated concurrent engineering processes. This technique has not only proved to be faster, but the simultaneous design process appears to require less engineering hours and results in products better adapted to the production process, which in turn results in better quality of the end product (Womack 1990).

The use of Virtual Design and Construction techniques in an integrated building process results in a large variety of different applications and analyses. Each of these applications aims to (partially) analyse, simulate and predict the quality of the end product and the characteristics of the process to build and operate the product. Figure 2.3 presents a simplified outline of a concurrent

property development process including the main decision-making processes. Figure 2.4 shows a number of Virtual Design and Construction methods that can be applied to facilitate the design of the product and process.

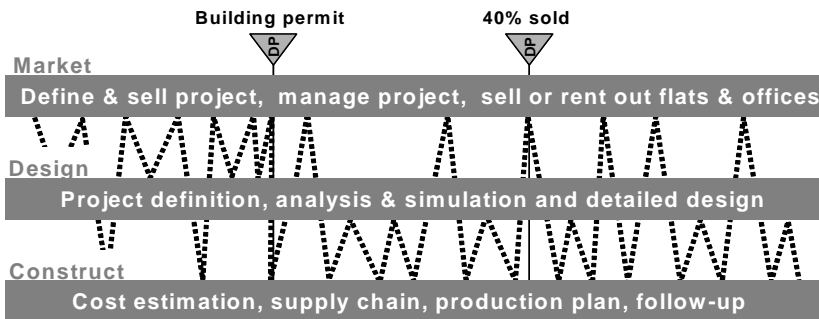

Figure 2.3: Outline of a property development project, including a schematic representation of the decision-making process. The dotted line represents the main decisions between a number of concurrent key-processes in the property development process.

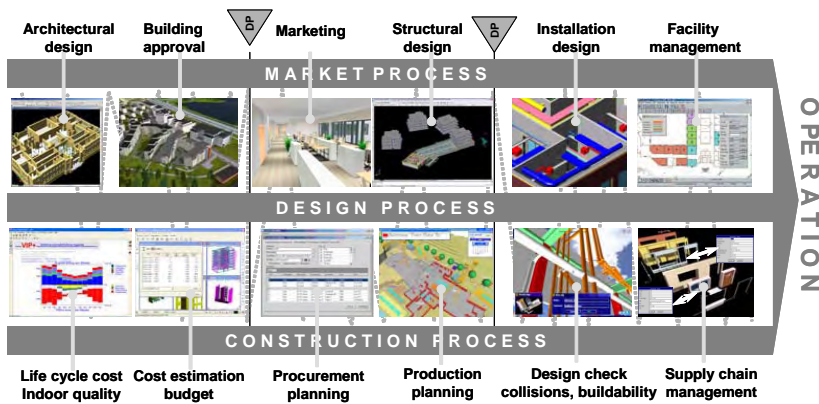

Figure 2.4: Applications of Virtual Design and Construction techniques in a property development project facilitate the communication in the decision-making process.

Examples of the potential benefits of the application of Virtual Design and Construction techniques in a property development process can be summarized as follows:

- The process of obtaining a building permit process becomes faster and more efficient. Visualisation of the overall design improves communication and clarification, resulting in less complaints and misunderstandings of the layout and effects on the neighbouring environment.
- The sale process improves in early stages of the project. Selective price tags on attractive flats can more easily be determined by the developer. Potential customers can get a visual impression of the layout and the view from the flat before they sign the contract.
- Life cycle cost can be estimated early and the design can be changed to meet design targets.
- Early procurement of critical components with long delivery times, such as windows, can be made earlier with lower prices as a result.
- Integrated structural and installations design leads to fewer collisions in the design and hence, less re-work on the construction site.
- Integrated design and production planning (4D), improves the build-ability of the design, the site layout and work-flow on the construction site with less waste on the construction site as a result.
- Integrated design, bill of quantity take-off, cost estimation and supply chain management reduces the waste related to waiting for and storage of components and material on site.
- Handover of as built model for e.g. facility management increases the value for the owner.

The applications of different Virtual Design and Construction methods are dependent on each other and should be applied in an iterative manner in which several analyses are repeated until a satisfying solution is found. The iterative and interdependent use of the Virtual Design and Construction applications puts high demands on the definition and structure of the data that supports the various analyses. In the next section I look deeper into the development of CAD and data schemas.

2.2 Product modelling

The introduction and adaptation of CAD systems in the AEC (Architecture, Engineering and Construction) industry started in the '60s and '70s where electronic drawing boards speeded up the 2D drafting work by engineers. Applications were already available at that time for basic 3D modelling, including functionality for quantity take-off and generation of drawings. The applications were running on expensive mainframe computer systems and were thereby only available for major engineering offices that could ensure maximum utilization of the systems. The transition from mainframe computer systems to personal computers in the '80s allowed for a wider spread of CAD applications in the construction industry. At that time the applications were mainly used for the production of 2D drawings. The development and adaptation of 3D modelling emerged in the late '80s and early '90s. Since then developments of software and hardware have resulted in increasingly sophisticated CAD packages that today can run on laptop computers for relatively little cost.

Today's CAD systems can be applied for much more than 3D modelling and the generation of drawings. However, the potential of these systems is often not fully utilized and application is limited to generating and exchanging traditional documents, such as 2D drawings, in a digital format. The traditional way of exchanging information in the construction industry is document centred. Examples are 2D drawings, written specifications, manually calculated bills of quantities, etc. Although computers offer substantial help today in the production of these documents, the data exchange and management procedures are still focused on documents, which have an important legal status.

The development and use of computer-based models for the AEC industry has been discussed within international research and development communities for some time (Eastman 1992; Fischer 2004c; Gielingh 1989; Laitinen 1998). Different terms and concepts are used in discussions to denote these models and modelling systems. The most common terms are product modelling and product data technology. Recently, the concepts of a building information model (BIM), nD modelling and virtual building environment (VBE) have been added to the terminology describing information models for the AEC industry. A BIM is a computer model database of building design information, which may also contain information about the building's construction, management, operations and maintenance (Graphisoft 2002). An nD model is an extension of the BIM, which incorporates multi-aspects of design information required at each stage of the lifecycle of a building facility (Lee

2003). A Virtual Building Environment (VBE) is a “place” where building industry project staffs can get help in creating BIMs and in the use of virtual buildings (Bazjanac 2004). A virtual building is a BIM, or an nD model, deployed in software. I define BIM and nD models as product models.

A product model for the construction industry can be described as formal set of descriptions. Laitinen (1998) defines product data technology as a set of IT methods, tools and standards for the development and implementation of applications for the management, exchange and sharing of product data. The product data that is stored in the model can be defined as a representation of information about a project in a formal manner suitable for communication, interpretation or processing by human beings or by computers (Karstila 2001). This information concerns both process as product information such as information on geometry, planning, costs and work-documents (Amor 2001).

One of the main developed standardized schemas for the construction industry is the Industry Foundation Classification (IFC) by the International Alliance for Interoperability (IAI 2006). The IAI is an open international consortium of CAD vendors, such as Graphisoft, Autodesk, Bentley, Nemetschek and many other organisations. The IAI defines interoperability as an environment in which computer programmes can retrieve data automatically, regardless of the type of software or source of data (IAI 2006). The eventual goal of the IAI is to develop product data models for sharing information between software tools, which are utilised throughout the building industry. This is done by specifying how the ‘objects’ (products and processes) that a construction project consists of, such as doors, walls, rooms, etc., should be represented electronically. Each specification is called a ‘class’. The word ‘class’ is used to describe a range of things that have common characteristics. For instance, every door has the characteristic of opening to allow entry to a space; every window has the characteristic of transparency so that it can be seen through. Door and window are names of classes. The classes defined by the IAI are, as mentioned earlier, termed ‘Industry Foundation Classes’ or IFCs. A wall object created in one application can be exchanged with another IFC compliant application, which recognises the wall object and the accompanying specifications.

The work on IFC by the IAI is promising, but there is a need to be realistic about IFC (Ekholm 2000). It is a system built by many people from many countries during a relatively short period of time. This fact is strongly reflected in the model; it is very large and not fully consistent and has a variety of details in different parts and different solutions to similar problems within different areas. The model is hard to get an overview of and it takes a lot of time and

effort to understand it. Regardless of these shortcomings, the main impression is that IFC is an effort in the right direction and that it is steadily improving. Whether or not it will be named IFC or something else in the future is hard to tell.

2.3 Project planning

Construction managers coordinate and supervise the construction process from the conceptual development stage through construction, making sure that the project gets done on time and within budget. Therefore, project planning is a critical task in the management and execution of construction projects. It involves the choice of construction methods, the definition of tasks, the estimation of the required resources, durations for individual tasks, the identification and coordination of any interactions among the different work tasks and use of common resources (Clough 2000). A good production plan creates the foundation for cost control, resource planning, supply chain management, and the scheduling and follow-up of construction work.

The planning process starts with the definition of a Work Breakdown Schema (WBS) for the project. The WBS displays and defines the project to be developed and relates the elements of work to building parts. It also provides the base for cost estimation and scheduling of the construction work.

The planning process of a construction project evolves commonly through several stages:

1. The conceptual design or the program stage where functional requirements and definition of the construction project are set. In this stage plans and estimations are preliminary and large uncertainty exists. In some sense these plans can be seen as the upper limits regarding time and cost.
2. Preliminary design or the quotation phase for the contract where major components are selected, such as the type of sub- and superstructure of the building, selection of crews, subcontracting of construction work and the type of major equipment to use in the construction phase. At this stage master plans are constructed giving the overall picture of a construction project in terms of time and costs.
3. Detailed design and construction where shop drawings are made, the construction site is established and construction work starts. Weekly work

plans and look-ahead schedules are commonly used to support the management of supplies and construction work.

In all these stages the WBS is defined and used on different level of detail to support the estimation and scheduling work.

2.3.1 WBS, quantity take-off, cost estimation and scheduling

A WBS establishes a common frame of reference for a construction project. It divides the project into a hierarchical structure of manageable parts or work-packages. The structure enables resource loading of schedules and cost estimations at different level of detail. It is also used to identify parts of the project that can be sub-contracted.

The 3D model of the building contains the artefacts to be constructed and is commonly organised in an object oriented structure. The 3D model created in the design process is often not organised according to the WBS of the project. One needs to connect the identified work packages with the objects in the 3D model that are supposed to be constructed.

The first step is to organise the objects in the 3D design model(s) according to the WBS of the project, illustrated in Figure 2.5. The most common technique to map objects to identified work packages is to add existing 3D objects to CAD layers representing the desired level of the WBS. The resulting production adapted CAD model, referred to as production model, can be further refined by adding objects specifically used for production purposes, such as shoring, form work, etc.

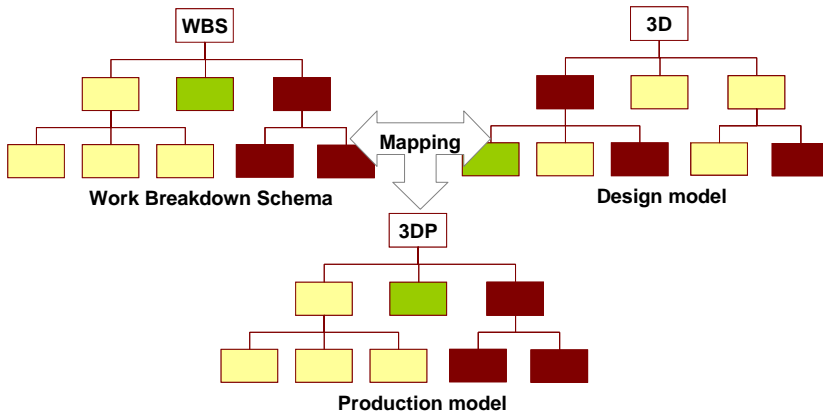

Figure 2.5: Mapping the WBS to the 3D design model to create a 3D production model.

The second step is to define recipes for every work package in the production model, Figure 2.6 and Figure 2.7. A recipe contains a number of methods (i.e. tasks) that are required to complete a specific type of work. Methods for the recipe “1.3 cast in place concrete column” can for example include the following methods: “install form”, “tie reinforcement”, “cast concrete”, “remove form” and “finish surface”. For each of these (standard) tasks it is known what resources are required per unit work (m, m2, m3, piece, etc.).

Recipes or code accounts are often available on company or national level and express the cost of material and work and man hours needed per unit of the building part to be produced on different levels of abstraction. By using computer supported code account systems and production models containing code accounted 3D objects one can support the planning process through:

- Making quantity take-offs from the 3D model where the quantities of specific building objects can be cost estimated using code accounts and recipe databases of building parts. The construction cost of a building can be summarised on any level of detail.
- Making quantity take-off from the 3D model where the quantities of specific building objects in a particular location can be time estimated using codes and recipe databases of building parts. These time estimates for specific locations can be used to schedule the work, the

supply chain of material and design information to site and the cash-flow throughout the construction stage of the project.

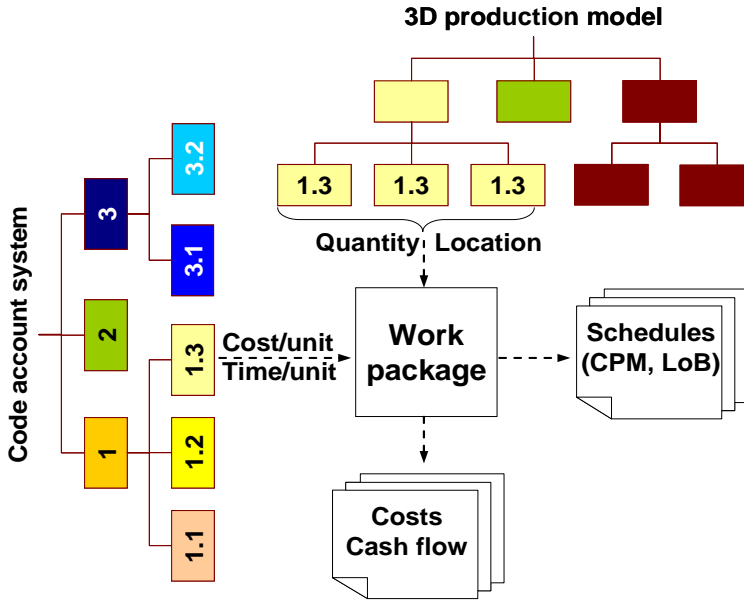

Figure 2.6: Cost estimation and scheduling process supported by a 3D production model. Objects from the 3D production model are mapped with corresponding recipes from the code account system, resulting in a specification of work methods for a specific quantity and location in the project (i.e. a work package).

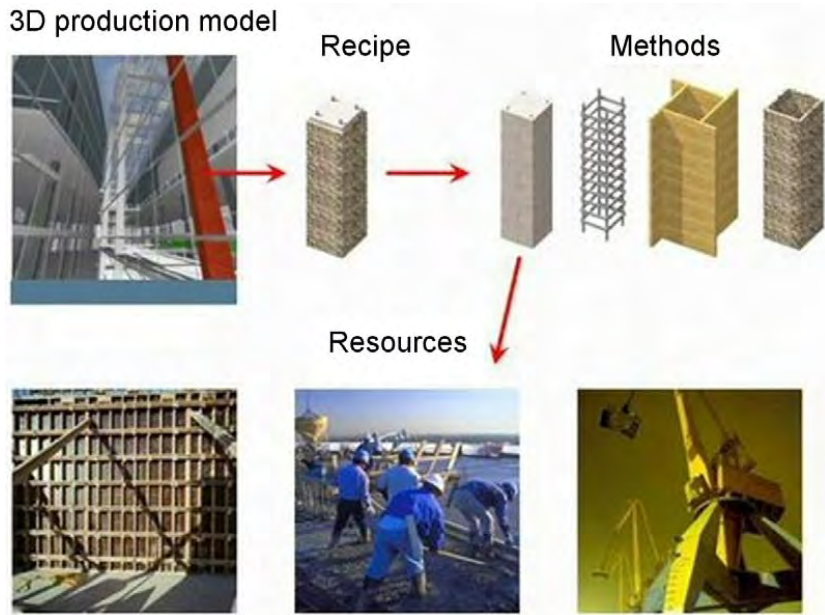

Figure 2.7: Cost estimation and scheduling process supported by a 3D production model. A recipe is mapped to a 3D object from the 3D production model. The recipe contains methods (i.e. tasks) for which it is known what resources (materials, equipment, man hours, etc.) are required per unit work (m, m2, m3, piece, etc.). Illustration by (Graphisoft 2006)

2.3.2 Scheduling methods

Using the WBS planners decompose a project into activities that they associate with one or more building components that make up the project. In addition to assigning dates to project activities, project scheduling is intended to match the resources of equipment, materials and labour with construction work over time. Good scheduling can eliminate bottlenecks in the production process, facilitate the timely procurement of necessary materials, and ensures an efficient and timely delivery of the project for the client. In contrast, poor scheduling can result in considerable waste as labourers and equipment wait for the availability of needed resources or the completion of preceding tasks. The scheduling process is a challenging task in which planners need to carefully

design time-space buffers between activities so that on one hand the productivity for each crew is not slowed by time-space conflicts and lack of work-space and on the other hand the overall schedule is not lengthened due to excessive use of time-space buffers. In the next sections I present two different methods to schedule construction work: activity-based scheduling and location-based scheduling.

Activity-based scheduling

Today's commonly used technique to schedule the construction process is the activity-based Critical Path Method (CPM) (Kenley 2004). Activity-based scheduling methods, such as the CPM, were originally developed for processes that are dominated by complex and sequential assemblies of pre-fabricated components, involving discrete activities on a predestined discrete location, such as the development and assembly of a satellite. The method is applied in most of today's construction projects, and powerful and affordable software is available to set up a CPM-based schedule.

Based on calculating how long it takes to complete essential activities and analyzing how those activities interrelate, CPM provides a visual and mathematical technique to plan, analyse, schedule and monitor construction projects.

The main concept of the method is that a limited set of activities control the entire project (Clough 2000). These activities together are called the critical path. If the activities on this critical path can be identified and managed properly, the fate of the entire project can be controlled. Non-critical activities can be rescheduled and resources for them can be reallocated flexibly, without affecting the whole project. Some activities are serially linked. In certain cases, the activities can be run in parallel, because they are independent of each other and can start simultaneously.

The final network is often presented in a bar chart known as Gantt chart that describes the proposed schedule of the project. The customary approach is to prepare a master schedule of this kind that is used as a basis for plans of more specific nature, like more detailed short-term plans (Koskela 1999). These CPM schedules are in many cases discipline oriented and do not explicitly consider the spatial layout of a project nor the spatial interaction between trades. Typical problems that arise as a result of this planning practice are sub-optimization, out-of-sequence work and inefficient work- and space buffers

(Fischer 2004a). In the next section location-based scheduling is considered as an alternative to scheduling with the CPM method.

Location-based scheduling

As noted in the previous section, activity-based scheduling methods, such as the CPM, are well-suited for processes that are dominated by complex and sequential assemblies of pre-fabricated components, involving discrete activities on a predestined discrete location. However, many construction projects have a different character. They typically consist of large amounts of on-site fabrication, which involves continuous or repetitive work at different locations. These characteristics of construction align more closely with location-based scheduling.

Location-based scheduling is not a new concept and has been a research issue for many years. Practical use in construction has however been limited, mainly due to the strong tradition of activity-based planning and the absence of software packages that support location-based planning. Research and development regarding location-based scheduling methods has been carried out since the 1940s and variations of the method appear in literature under different names, such as 'Line-of-Balance', 'Flowline', 'Construction Planning Technique', 'Vertical Production Method', 'Time-Location Matrix Model', 'Time-Space Scheduling Method', 'Disturbance Scheduling', and 'Horizontal and Vertical Logic Scheduling Logic for Multi-Storey Projects' (Harris 1998; Kenley 2004; Mohr 1991). I adopt the Line-of-Balance (LoB) scheduling technique as an example of a location-based scheduling method.

Line-of-Balance is a visual scheduling technique that allows the planner to explicitly account for flow of a project (Seppänen 2004). Line-of-Balance uses lines in diagrams to represent different types of work performed by various construction crews that work on specific locations in a project. The definition of spatial subdivisions, defined as a Location-Breakdown Structure (LBS), is the backbone of the scheduling and control work with the Line-of-Balance diagram. The definition of a LBS and preparing the building quantities according to this structure goes hand in hand with the definition of the WBS for a project.

Figure 2.8 (see also Paper III, Figure 1) shows the most common deviation types that can be identified by using Line-of-Balance diagrams. These deviation types indicate scheduling mistakes and opportunities to plan for a stable and continuous flow of work through locations of a project. Figure 2.8

summarizes the deviation types in one Line-of-Balance diagram. Identifying deviations that can affect the execution of work on site and manipulating the schedule to address these issues is much easier and more feasible compared to the use of activity-based scheduling methods, such as CPM.

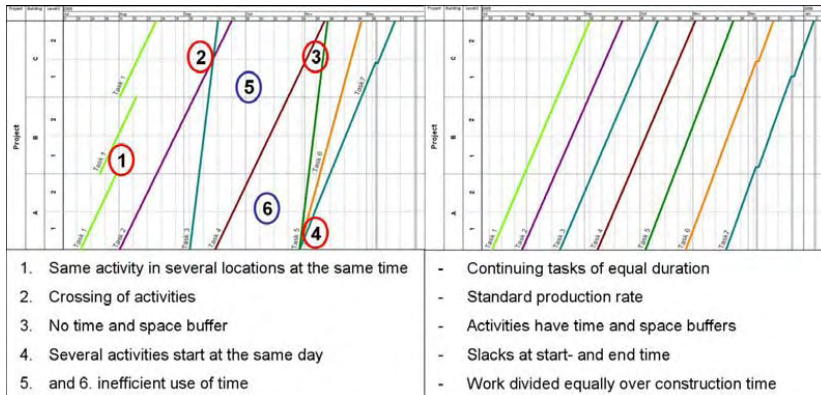

Figure 2.8: Examples of Line-of-Balance diagrams. Locations are represented on the Y-axis and project time on the X-axis. The lines represent construction operations by crews. (Left) Common deviation types (no. 1 – 6) in a Line-of-Balance diagram. (Right) Typical solutions to deviations in a Line-of-Balance diagram

Two main principles are used to minimize the deviations listed in Figure 2.8 and to plan for work-flow with Line-of-Balance diagrams: synchronization and pacing.

- Synchronization means that planners aim to achieve a similar production rate for all activities. A synchronized schedule can be identified by parallel lines that show a constant time-space buffer between different tasks.
- Pacing means that the activities are scheduled to continue from one location to another without interruptions.

Scheduling a project with Line-of-Balance also includes monitoring and control of the actual construction work against the planned construction work. Monitoring of production includes gathering data about completed amounts and resources, compared to today's common practice in construction in which

often only the production costs are monitored. When monitoring uncovers a deviation from the plan, the cause for this deviation is sought, the consequences of the deviation are considered and an action is taken to correct the deviation.

Lines are drawn in the planned Line-of-Balance diagrams that represent the actual production (dotted lines, Figure 2.9). These lines provide the users with information about the history of a task. Users, such as planners, can in other words understand where and when a task has been performed in the project. Based on the actual performance of a construction task a forecast is made for the execution of the construction work that is left (dashed lines, Figure 2.9). This forecast can be used to update the Line-of-Balance diagram to allow for possible required changes in production strategies.

Figure 2.9 shows an example of a Line-of-Balance diagram in which a number of monitoring and control actions have been marked. The red line represents the control-moment. The planner realizes that the painting work and installation of fittings is disrupting production. The planner adds resources (Figure 2.9 no. 1, steeper line represents higher production rate) to the painting work to speed up the work and reschedules the work left on the installation of fittings to a later point in the project (Figure 2.9 no. 2). In addition, the planner slows down the floor covering work (Figure 2.9 no. 3) to create enough time and space between the installation of fittings and floor covering work.

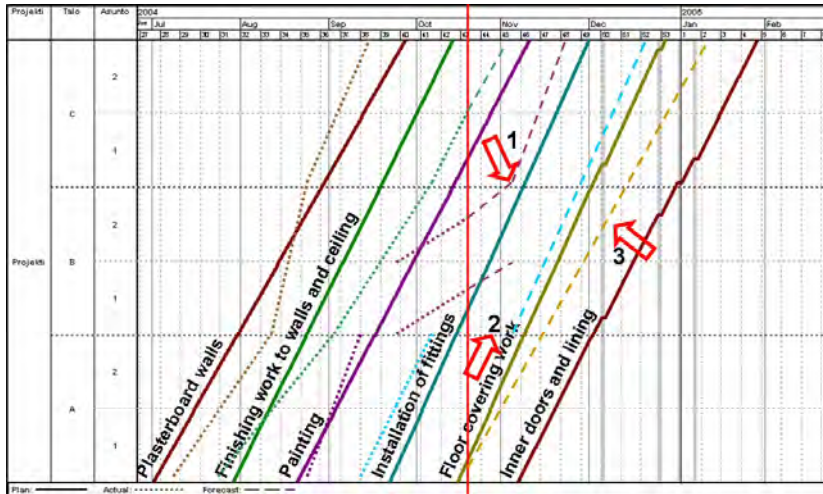

Figure 2.9: Monitoring and control of construction work with Line-of-Balance diagrams (Appelqvist 2005). Locations are represented on the Y-axis and project time on the X-axis. Number 1-3 present control actions: 1. Increased production rate, 2. Split and reschedule a task, and 3. decrease production rate.

Line-of-Balance scheduling is an increasingly applied scheduling method and is especially addressed in the Lean Construction community as a means to create and ensure work-flow in construction projects. In the next section I discuss Lean Construction and the relation to Line-of-Balance scheduling and Virtual Construction.

2.4 Lean Construction

As noted in the Introduction (Chapter 1), Lean Construction is to a great extent an adaptation and implementation of Japanese manufacturing principles within the construction process. Even though the guiding principles were not formulated until after nearly ten years of research and application, one may deduce that from the beginning they were: While delivering the project, maximize the value for the client and minimize the waste (Bertelsen 2004).

Koskela suggests a Transformation Flow Value (TFV) understanding of construction, based on principles from the manufacturing industry (Koskela

1992). The transformation view of production has been dominant in construction, which is based on the idea that a combination of production factors results in a finished product. Work-flow is defined as the movement of tasks through a work process (Hopp 1996). The transformation concept is considered limited in the sense that this view does not recognize that there are other phenomena in production than transformation. The transformation view is not especially helpful in figuring out how not to use resources unnecessarily. The flow view of production identifies four stages – processing, inspection, waiting and moving – of which only the processing stage is transformation, the others are not (Koskela 1999).

Lean Construction research is not limited to studying the production process from a transformation and flow view, and includes all stages of the project delivery process, ranging from client briefing to operations and maintenance. The introduction of the concept of flow is probably the most important contribution to the understanding of the construction process made by the Lean Construction research community (Bertelsen 2004). The production in construction is of assembly-type and there are different types of flows connected to the end product. There are at least seven resource flows (i.e. preconditions) that unite to generate the task result, each of which has to be planned and controlled (Koskela 1999), Figure 2.10. Many of these resource flows are of relative high variability and as a result the probability that they negatively impact the task result is rather high. For example, it is not uncommon that a shop-floor drawing is missing at the intended start of the construction task or that external conditions such as rain or snow affect the work on site. Also, the productivity of workers may vary and the available space for work execution is often difficult to plan for. Due to the variability of the resource flows a value of less than 60% of planned task realization is quite normal (Ballard 1998). Planning these preconditions so that the work on site is not interrupted is an inherently difficult task.

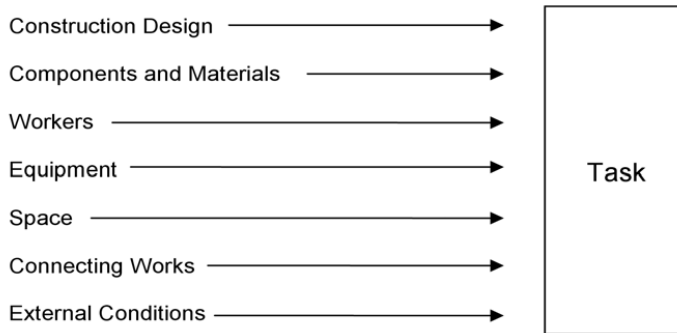

Figure 2.10: The preconditions for the completion of a construction task (Koskela 1999)

Tasks and flows have to be considered simultaneously in production management. The realization of tasks heavily depends on flows, and the progress of flows in turn is dependent on the realization of tasks. The difficulty to plan tasks and flows is reflected in the high levels of non-productive time as typically found in construction. In the Introduction Chapter I referred to a survey of seven Swedish construction sites in which detailed studies were made of the time spent by workers on a construction site. The study shows that a construction worker spends only 15-20% of the time on direct work. Approximately 45% is spent on indirect work (preparations, instructions, getting material, etc.). The remaining 35% is spent on redoing errors, waiting, disruptions, etc., i.e. a waste of time (Josephson 2005).

2.5 Work-flow management

I define two levels of work-flow management in projects:

- Macro-management of work-flow concerns the management of the flow of resources through locations in projects.
- Micro-management of construction tasks concerns the planning and control of the preconditions for the successful completion of tasks.

In section 2.3 of this Chapter the customary approach to project planning is introduced, in which the use of the WBS is explained. Using this schema, planners decompose a project into activities that they associate with one or more building components that make up the project. The customary approach

is to prepare a master schedule that is used as a basis for plans of more specific nature, like more detailed short-term plans, such as phase schedules and six week look-ahead schedules (Koskela 1999). These schedules are in many cases discipline oriented and do not explicitly consider the spatial layout of a project nor the spatial interaction between construction trades. Typical problems that arise as a result of this planning practice are sub-optimization, out-of-sequence work and inefficient work- and space buffers. Updating of the master schedule is usually deficient, and consequently task management, at the short term, is largely done informally by the foremen or left to the teams on site to be taken care of by mutual adjustment (Koskela 1999). As a result, the macro-management of work-flow, which concerns the management of the flow of resources through locations in projects, is left to ad hoc management on site where there is little opportunity to change construction execution strategies.

The use of the CPM method for the purpose of micro-management leads to very detailed schedules that are difficult to use, communicate and update (Huber 2003). Using the CPM method for micro-management also implies that it is assumed that progressive subdivision of tasks eventually will transform the description of what should be done into how it should be done. As a result of these practical and methodological difficulties the tasks' preconditions are often not explicitly planned for, which leads to work under sub-optimal conditions. Tasks are routinely commenced or continued without all preconditions realized, leading to lessened productivity and waste in the construction process.

Figure 2.11 shows the relation between the planning of tasks that should be done and a mechanism for micro-management to ensure that tasks will be done. Methods and systems are starting to become available for the micro-management of construction tasks of which the Last Planner method currently is the most common technique.

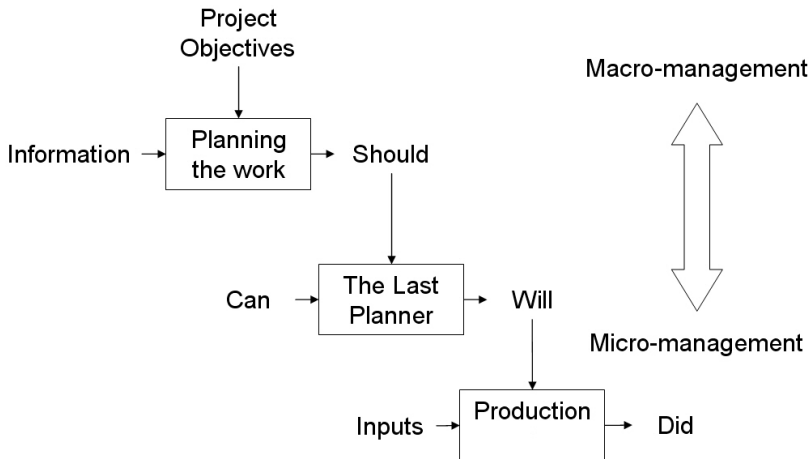

Figure 2.11: Work-flow management in relation to the Last Planner method. Last Planner is an example of a method to ensure that tasks that should be done, will be done (Ballard 2000).

The Last planner method (Ballard 2000) is based on the following five principles (Koskela 1999):

1. The first principle is that the assignments should be sound regarding their prerequisites. This principle has also been called the Complete Kit (Ronen 1992). The Complete Kit suggests that work should not start until all the items required for completion of a job are available. Thus, this principle pursues the minimization of work under suboptimal conditions.
2. The second principle is that the realization of assignments is measured and monitored. The focus on plan realization diminishes the risk of variability propagation to downstream flows and tasks. For this purpose metrics can be used such as, Percent Plan Complete (PPC). PPC is the number of planned activities completed, divided by the total number of planned activities, and expressed as a percentage.
3. The third principle dictates that causes for non-realization are investigated and those causes are removed. In this way, continuous in-process improvement is realized.

4. The fourth principle suggests maintaining a buffer of tasks which are sound for each crew. If an assigned task turns out to be impossible to carry out, the crew can switch to another task. This principle is beneficial in avoiding lost production (due to starving; a situation in which crews run out of work) or reduced productivity (due to suboptimal conditions).
5. The fifth principle suggests that in look-ahead planning (with time horizon of 3-4 weeks) the prerequisites of upcoming assignments are actively made ready. This principle works on the one hand as a pull system for activities on site, and on the other as a means to minimize excessive buffers of work, time and space.

Kenley (2004) argues that Last Planner is a typical example of a method for management of construction tasks that is derived from and limited to the application of an activity-based scheduling technique, such as the CPM method. Activity-based methods are based around discrete activities that limit the identification of work-flow.

2.6 Production simulation

Virtual environments, such as virtual reality (VR) and 4D CAD, promote improved understanding of construction operations (Li 2003). Construction projects have unique spatial configurations and the spatial nature of projects is very important for planning decisions (Akbas 2004). 4D CAD models provide planners with a spatial insight in the scheduling process of construction operations, which is not clearly and effectively provided by using 2D drawings in combination with CPM schedules or Line-of-Balance diagrams.

4D CAD models are typically created by linking building components from 3D CAD models with activities that follow from CPM schedules, e.g. (Koo 2000; Tanyer 2005). Building components that are related to activities that are ongoing are highlighted. The 4D CAD model provides the user with a clear and direct picture of the schedule intent and helps to quickly and clearly communicate this schedule to different stakeholders in a project. 4D CAD models allow project participants to simulate and analyze what-if scenarios before commencing work execution on site (McKinney 1998).

Common for projects using 4D CAD is visualization of design decisions and improved communication of these decisions in the design phase (Woksepp 2005). Based on Japanese experiences, Nakagawa (2005) illustrates the importance of visualization for the maintenance of a synchronized and paced

work-flow and for the implementation of Lean Thinking in construction. Construction site workers tend to focus on their own tasks and therefore become indifferent to other related activities, which often creates waste in the form of rework and out-of-sequence work, particularly in projects with a large number of activities and crews. Proper visualization of overall project progress is encouraging workers to improve their work and the coordination with other crews, which facilitates work-flow while waste is reduced (Nakagawa 2005).

Most of today's 4D CAD models are used to communicate schedule intent, often at a macro-level in a project, using building components from a 3D CAD model that are linked to activities that follow from activity-based scheduling methods. There are a number of research initiatives that aim to extend the use 4D models beyond this use (Akbas 2004; Akinci 2002; Mallasi 2006).

Akinci et al. (2002) formalize and model space usage for construction activities in 4D CAD models, resulting in 4D CAD models that include different types of spaces. These models are referred to space-loaded 4D CAD models (Akinci 2002). The formalization and modeling methods provide insight into various types of spaces that are related to specific types of construction activities and potential conflicts (e.g., material space, labor space, building component space, etc.). The method provides insight in the space use of construction tasks' prerequisites and the relations between these spaces. The method does not provide insight into the efficiency of designed time-space buffers between different activities, nor does the method address the flow of construction work through locations.

Akbas (2004) proposes a geometry-based process model (GPM) that uses geometric models to model and simulate work-flows and work-locations. This method provides spatial insight into the planning of work-spaces and space buffers for repetitive crew activities. The method provides insight in the flow of crews through locations in a construction project, but does not address the identified preconditions for the successful completion of a construction task, Figure 2.10.

In summary, the use of 4D CAD to manage work-flow on a macro- and micro-level is limited due to practical and methodological reasons. I made this observation in the test cases that are presented in the next chapter. Using these test cases I developed and applied a process model for the management of work-flow on a macro- and micro-level in construction.

3 RESULTS FROM THE TEST CASES

This chapter presents the main results from the five test cases that are part of the research. The test cases provide insight in how I developed and refined my research definition and results.

3.1 Test Case I – nD modelling

The main motivation to conduct this study was to use product models beyond their common, but limited, use in 3D. The following model dimensions are studied:

- Traditional 2D drawings and documents are partly generated from 3D models and linked to these models.
- Various types of 3D models from different disciplines are modelled and integrated in one environment.
- Multiple production schedules are linked to 3D models resulting in 4D models.
- 5D cost estimation is developed by linking different 3D models to cost estimation recipes.
- Model use and configuration of material parameters by a ready-mixed concrete supplier provides an additional dimension to the use of product models.

The development and implementation efforts were mainly driven from the perspective of cast-in-place concrete construction. The application of different dimensions of product models provided me with a number of insights and experiences that formed the basis for my research work.

At present there appears to be no single model that serves the information needs of all the different project participants through the phases of a project. The absence of such a model is mainly due to technical and practical reasons:

- First of all, product models do not contain all information that is required to produce all discipline-specific views, such as plans, sections, elevations, schedules, etc. The lack of this information is due to unavailability of adequate modelling tools, required effort to add this information to product models and the effort to extract this information.
- Secondly, views of product models differ between actors (Paper I, Figure 4 A). Generating specific views from a multi-disciplinary central model is constrained by these different views.
- Thirdly, certain information is associated with a model, but not necessarily part of a model. The vast majority of information exists in unstructured documents and there is currently little linkage between this information and model-based information.

Thus, instead of one all-including model there appears to exist a number of discipline-specific models. These models are not independent and isolated models, but are related to each other. Using the different models I was able to model and generate different views of model-based building information. For example, I mapped (i.e. linked) a cost estimation hierarchy (i.e. breakdown-structure) to different 3D models, that were all structured according to discipline specific views of building information. During this modelling and mapping process of discipline-specific views I searched for one common denominator for the different views. I found that location definitions (e.g. a specific type of room in an apartment on a building storey in a wing of a building) were used at different levels of detail by all disciplines in the project. This insight resulted in the fact that I reconsidered the common discipline-oriented Work-Breakdown Structure (WBS) of projects and I defined and adapted a Location-Breakdown Structure (LBS), as reported in Paper III, IV and V.

The modelling experiments in Test Case I provided me with hands-on experience of 3D and 4D CAD. 4D CAD was used as an instrument to introduce construction innovations and to evaluate construction alternatives for cast-in-place construction. This experience added to my understanding of the possibilities and constraints of the modelling technology and provided me with the insights and questions related to 4D CAD.

I found that the model objects used for design purposes are different from the objects used for simulation of construction operations. In order to create what I define as production models from architectural- and structural design models I decided to:

- Change the structure of the 3D CAD models, by which I regrouped objects to represent work packages and construction activities.
- Change the 3D CAD objects themselves by splitting and regrouping the objects. For example, large slabs were split in smaller objects to represent concrete pours.
- Add 3D CAD objects that were not present in the design models, such as concrete formwork and other types of temporary structures.

The 4D models that resulted from the 4D modelling process were used by industry professionals to study and compare different production technologies. It was generally agreed by these professionals that the 4D models help to communicate and understand alternative construction processes, but it was noted that the 4D models were limited in scope and limited to graphics. Evaluation of alternative strategies for the execution of work or changes in productivity could not easily be managed in the 4D models.

3.1.1 Results from Test Case I

I made the following observations of the 4D modelling and 4D analyses process, in which I define 4D modelling as those tasks related to creating the 4D model and 4D analyses as those tasks related to presenting and analyzing the 4D model:

- Current analyses of 4D models are mainly visual and provide project stakeholders with a clear, but limited, insight of construction planning information. The practice does not take advantage of the quantitative data in 4D models. This insight formed the basis for Paper II.
- Questions about scope of the 4D model related to the contents of the model. I realized that there are many more aspects relevant and related to modelling construction operations than building components, such as formwork, but I wondered which aspects and how to include these in 4D models. Paper V and to a lesser degree Paper III present my suggested approach to address these questions.

- The objective of the 4D modelling process in Test Case I was to show and compare two alternative flows of construction operations. However, during the 4D modelling process I realized that the current scheduling method, the CPM method, which is used as a basis for most of today's 4D models, is not a suitable method to plan for the flow of construction operations. Paper III and Paper IV present an alternative to activity-based 4D modelling.
- Creating 4D models for work-flow management efficiently and effectively requires a process model that formalizes and integrates the 4D model contents, process and analyses. Paper III and Paper V present a proposed process model for 4D model-based work-flow planning and control.

3.2 Test Case II – Quantitative analyses using 4D models

Based on the 4D modelling experiences of Test Case I, I decided to look deeper into the use of 4D models to support quantitative analyses. From the first test case it became clear that 4D models are effective in providing project stakeholders with a visual insight of construction planning information. In Test Case II I used the case project from Test Case I (Paper II, 2. Industry Case Example) to illustrate how to analyze, compare and present 4D content quantitatively. I conducted this study together with researchers at CIFE, Stanford University.

Test Case II involved three types of analyses to illustrate the potential of 4D-content-based analyses, in which 4D content is defined as information present in a 4D CAD models, such as distances between concurrent activities.

- The first analysis originated from recognizing the spatial nature of construction work and the way in which work moves over a construction site during construction.
- The second analysis concentrates on the planning of temporary structures supported by quantitative data from 4D CAD models.
- The third analysis combines crew productivity and production costs with extracted 4D content.

For the first analysis we extracted used work-space areas per construction trade and distances between concurrent activities of different trades. Examples of

extracted data are included in Paper II, Table 2 and 3. Figure 5 and 6 (Paper II) present this data in graphs that provide users with additional representations of 4D CAD model information. Figure 6 (Paper II) shows the distances between formwork and reinforcement activities for every simulated construction day per two hour interval. The formwork and reinforcement activities are close to each other during days 3, 4, 5 and 6. On day 6 the activities overlap, as shown by the negative distance between the two construction trades. This overlap, or time-space conflict, was overlooked in the 4D CAD model, but became immediately obvious in the graph showing the distances between trades.

The second analysis exemplifies comparative analysis of 4D models by analyzing alternative plans for temporary structures. For example, it is analyzed how long and how much space the shoring in two construction alternatives needs. Data extracted from the 4D model includes the amount of space taken by shoring and the duration that is associated with the space. To compare the durations of shoring use for the same location and for the same amount of space, we split the required shoring for the construction alternatives into a number of different shoring locations (Paper II, Figure 7). The results of the analysis show that measuring the space taken by temporary structures and the time of temporary structures in a quantitative way supports comparing and evaluating alternatives for temporary structure plans in terms of the potential for time-space conflicts and efficiency of resource reuse. It also shows that using similar break-ups (i.e. division of locations) of temporary structures facilitates comparative analyses of different shoring plans.

The third analysis establishes a relation between a specific 4D content (i.e. distances between trades) and trade productivities (Paper II, Table 4). The analysis exemplifies how construction planners could benefit from using 4D content to analyze the impacts of planning decisions on the flow of construction work.

3.2.1 Results from Test Case II

From Test Case II it appears that 4D modelling is a promising approach to compare construction alternatives and to plan for work-flow, and the test case shows that:

- A common denominator is needed, in time and in space (i.e. locations), to facilitate comparative analyses of alternative 4D models. This insight is the basis for work in Test Case III, IV and V.

- By analyzing the graphs it becomes clear that not all spatial data from 4D CAD models become explicit in the typical form of 4D snapshots or 4D movies. The analyses show that additional presentations of 4D CAD model information, such as graphs, are needed to efficiently allocate work-space and space buffers between concurrent activities by construction crews.
- Extracted data from 4D models allows for novel presentation and analyses of construction planning information that can be of interest for construction planners.
- There are most probably more 4D contents that can be of interest for design, planning and control of the construction process, than the 4D contents that were extracted in Test Case II. Combined these contents can possibly result in sets of 4D contents, reasoning mechanisms and information presentations that are standardized for different types of analyses.

3.3 Test Case III – Location-based scheduling and 4D CAD

During my work on the first two cases I realized that the activity-based CPM method, used as a basis for most of today's 4D models, is not a suitable method to plan for work-flow. In Test Case III I studied the concept of work-flow and considered an alternative to activity-based 4D modelling. Based in the insights from Test Case I and II I started to study location-based scheduling techniques, since I had identified the importance and usefulness of locations in the scheduling process of construction work.

In Test Case III I define work-flow as the flow of resources through locations in projects, in which resources are defined as those prerequisites of construction tasks that have a spatial property, such as crews, material, temporary structures, etc. I focus on the flow of construction crews through locations in projects in this case.

The Line-of-Balance scheduling technique, which is one of the most common variants of location-based scheduling techniques, appears to provide better characteristics to plan for work-flow, compared to activity-based scheduling techniques, such as the commonly used CPM method (Paper III, 2.1 Location-based scheduling). The method does not explicitly address the spatial configuration of activities. The locations in Line-of-Balance diagrams provide some spatial information, but these are abstract representations of the real

world. I found that the use of a Line-of-Balance diagram also calls for a 4D CAD model to provide spatial insight of construction operations.

My practical 4D modelling experiences from Test Case I and II, combined with theoretical studies during Test Case III, provided me with the following insights and basis for the practical application in Test Case III:

- Planning for work-flow requires detailed 4D CAD models. A detailed 4D CAD model requires in its turn a detailed schedule, which is difficult to manage and manipulate when using the commonly used CPM method. The 4D CAD models themselves are also difficult to update to reflect schedule changes. As a result, most of today's 4D CAD models are modelled once and not updated.
- 3D CAD models on which most of today's 4D CAD models are based, are limited to building components. Planning for work-flow with a 4D CAD model requires further detailing of the building model. In Test Case I, I identified the need for additional objects and added these objects by splitting existing objects and by modelling new objects.
- Many aspects of construction operations are not directly related to building components, but do affect the flow of work on construction sites.
- Planning of work-flow in construction requires locations in order to plan the flow of resources through these locations. Most of today's 4D CAD models are not modelled and structured according to predefined locations.

I applied the Line-of-Balance technique in combination with 4D CAD to a case study project (Paper III, 3. Line-of-Balance combined with 4D CAD – Case study) to explore the possible benefits and shortcomings of the combined method. I worked together with a number of M.Sc. and PhD students and experts from the industry.

Based on the findings from the test case and theoretical studies I started to define a process model for the combined use of location-based scheduling and 4D CAD. This process model is further refined in Test Case V. The process model served as a basis for Paper IV and V.

3.3.1 Results from Test Case III

The application of both methods in Test Case III provided me with the following insights:

- The Line-of-Balance technique allows planners to quickly gain insight in the flow of resources through locations in projects and requires minimal effort to manipulate the schedule. Compared to CPM, the Line-of-Balance method facilitates the planning for work-flow.
- The 4D CAD model is a supplement to the Line-of-Balance diagram as it allows users to gain insight in the spatial configuration of scheduled activities. The 4D CAD model of the case study showed for example the concentration of different activities in one corner of the building on multiple floors, resulting in a lack of work-space and hazardous conditions for crews to perform safe and productive work (Paper III, Figure 4 and 5). This concentration did not become apparent from the Line-of-Balance diagram, but could be detected by using the 4D CAD model that was based on the Line-of-Balance diagram.
- The tight integration of location-based schedule data and location-based 3D CAD models allows for analyses of work-flow using 4D CAD and addresses some of the current limitations related to the creation and manipulation of a 4D CAD model. For example, the LBS of the Line-of-Balance diagram provides a structure for the CAD model and the location-based CAD data in its turn provides planners with a basis for the amount of work that should be scheduled per location.
- Test Case III showed that the use of a 4D CAD model provides insight in the relation between the LBS and building components from the 4D CAD model. Certain types of building objects partially overlapped multiple locations. This insight could not be gained from the Line-of-Balance diagram alone, but became clear from the 4D CAD model.
- Test Case III is limited to planning of how a task will be performed and does not provide the user with a clear picture whether a task can be performed. The planning and control of the prerequisites for the successful completion of a construction task is addressed in Test Case V.

- Currently, Line-of-Balance schedules concentrate on the scheduling of crew locations and do not specify the types of space that a location includes, or how the use of one location results in space requirements for another location. Management of work-flow should also include the management of different space-types, in addition to the management of resource-flow through locations. Space is in this respect considered as a resource that is related to a location and a task in a project.

3.4 Test Case IV – Work-space-based 4D models

Test Case IV applies the process model of Test Case III to a multi-storey timber housing project in Sweden. I conducted this study together with Anders Björnfort at Luleå University of Technology.

As a first step in Test Case IV, we developed a Line-of-Balance diagram based on the traditional CPM-based master schedule from the case project. Based on the LBS of this diagram we subsequently developed a work-space-based 4D model. We decided not to include the actual building components (e.g. walls and doors) in the 4D model and to focus solely on crew locations that we represented by 3D space objects.

The definition of the LBS was developed according to two stages in the construction process. The first stage concerns the work on the load-bearing structure in which the lowest definition-level for locations is an apartment. The second stage concerns the construction finishing work. Construction finishing work is performed during the second stage in partially overlapping locations. As an example the concurrent work in an apartment and around a services shaft can be given (Paper IV, Figure 5 and 6, and Table 1: deviation type 3). The same services shaft is part of several apartments. We found that this partial overlap of work-spaces is a situation that is difficult to manage with the Line-of-Balance technique alone.

A possible solution is the use of a more detailed spatial division in the definition of the LBS for a Line-of-Balance diagram. However, a highly detailed LBS complicates the planning with and management of the Line-of-Balance diagram. Detailed locations can become too abstract in the sense that they no longer represent clearly identifiable physical locations. Line-of-Balance diagrams are best used for planning of construction work in a well-defined spatial system, such as a building storey consisting of apartments, divided into rooms. This type of static spatial hierarchy of work-spaces is not present during all stages of the construction process. The distributions of and

the boundaries between work-spaces are generally more complex and less clear. 4D CAD models are in this respect complementary to a Line-of-Balance diagram to provide with additional insight in the spatial irregularities of construction work.

We defined the LBS for the Line-of-Balance schedule according to stage one of the construction process and the LBS for the 4D work-space model according to stage one and two. In our analyses of the Line-of-Balance diagram we identified a number of deviations (Paper IV, Figure 6) according to the deviation types listed in Figure 1 (Paper IV). We subsequently used the 4D model to analyze the construction process from a work-flow perspective, with a special focus on the identified deviation types in the corresponding Line-of-Balance diagram. The results of the combined analyses are presented in Table 1 (Paper IV).

3.4.1 Results from Test Case IV

The application of both methods in Test Case IV provided us with the following insights:

- The main strength of the Line-of-Balance scheduling technique is the possibility of obtaining a synchronized and paced planning of operations in a well-defined spatial system, which creates opportunities for construction work to flow unhindered from work-space to work-space.
- Complex spatial configuration of work-spaces is difficult to manage with the Line-of-Balance technique alone and calls for a 4D model.
- A 4D model provides additional insight in the spatial context of scheduled construction activities and allows for more detailed evaluation of different production plans, work methods and design decisions.
- 4D models based on spaces are suitable for work-flow analyses, but building component-based 4D models are required to facilitate for example constructability analyses and supply chain management. A 4D work-space model can in this respect be considered a supplement to the common building component-based 4D model.

- The application of Virtual Design and Construction methods can facilitate the application of principles from Lean Construction and vice versa.

Scheduling for work-flow was limited to construction crews in Test Case IV. In Test Case V I study how additional resources that can affect the flow of work can be included in a 4D model, such as materials, temporary structures and equipment.

3.5 Test Case V – Macro- and micro-management of work-flow

Test Case V extends and applies the process model from the third case. Based on insights from mainly case III and IV I consider work-flow of construction work in this case on two levels: a macro- and a micro-level.

Macro-management of work-flow involves the management of the flow of resources through locations in projects. Macro-management of work-flow relies on the combined use of the Line-of-Balance scheduling technique and 4D models, as proposed in Test Case III. I define this level of 4D models as 4D macro-models.

Micro-management of work-flow concerns establishing a short term look-ahead planning by which preconditions (Paper V, Figure 1) are spatially planned and controlled that need to be satisfied for the execution of construction tasks. Micro-management requires a different approach compared to macro-management, since the Line-of-Balance method, in its current form, is not a suitable method to plan the preconditions for a construction task spatially. There are a number of issues that need to be addressed in order to use the Line-of-Balance method for micro-management of construction tasks:

- Line-of-Balance schedules currently concentrate on the scheduling of crew locations and do not specify the types of space that a location includes or how the use of one location results in space requirements for another location.
- The spatial distribution of locations can be too complex to be represented in a symbolic 2-dimensional tree of locations, as used in Line-of-Balance diagrams.
- Different construction trades work according to different spatial distributions.

- Spatial distributions can change as the project progresses. The LBS of today's Line-of-Balance diagrams is often based on the spatial distribution of the final product, but this distribution might not be applicable for all types of construction work.

I therefore suggest that micro-management of construction tasks is carried out in what I define as 4D micro-models. The 4D micro-model is based on the 4D macro-model, but is more detailed and is created for look-ahead planning purposes, typically with a time-span of three weeks. Paper V includes a process model for the management of work-flow using a 4D macro- and micro-model.

Micro-management of work-flow requires detailed 4D models by which the prerequisites for a construction task can be controlled. In Test Case III I found that the contents of most of today's 4D models are too limited to represent these prerequisites. I therefore suggest that these models use generic spaces that can be used for abstract representation of the tasks' prerequisites.

Based on my suggested process model (Paper V: 4. Proposed Method) I created a 4D macro- and micro-model for a complex and large-scale industry case study project. The 4D macro-model is based on the Line-of-Balance method and is used as a basis for more detailed 4D micro-models (Paper V, Figure 4). For the 4D micro-model I established a grid of semi-transparent 3D space objects that serve as locations for tasks' prerequisites. I based the dimensions of the objects on the minimal size of the locations for task prerequisites that should be manageable with the 4D micro-model. By stepping through the 4D model with a one-day interval I selected one or more space objects from the grid for every scheduled construction task on a simulated construction day by which I allocated work-space for construction crews. I subsequently used the 4D micro-models to study work-space allocation by analysing the number and distribution of allocated locations (Paper V, Figure 5).

3.5.1 Results from Test Case V

The application of 4D macro- and micro models in Test Case V provided me with the following insights:

- The 4D macro-model is useful to perform constructability analyses and to study the overall flow of work in the project.

- The 4D micro-model enables the spatial allocation of locations for construction tasks' prerequisites and provides planners with an instrument to control these prerequisites spatially.
- The 4D micro-model can be reduced to locations to allow for detailed analyses of space-usage.
- Using a grid of project locations facilitates the modelling- and analyses process (visual and quantitative) and provides a clear structure of the, in the case of Test Case V, very complex, LBS
- Although I limited the planning exercise to the planning of one prerequisite for construction tasks, the proposed method can also include other prerequisites. The allocation of locations for these prerequisites can probably partly be automated with appropriate mechanisms.
- The relation between different types of space use is important for planning decisions and should be included in the process model.
- Sharing of locations for different types of space use is also important for planning decisions and should be included in the process model.
- The proposed process model partly relies on Lean Construction principles. As noted in Test Case IV, I believe that this and other combinations of Virtual Design and Construction with Lean Construction can contribute to the value of the end product and the reduction of waste in the construction process.

3.6 Summary of test case results

The figure below summarizes and categorizes the main results from the test cases and indicates the relations between the test cases.

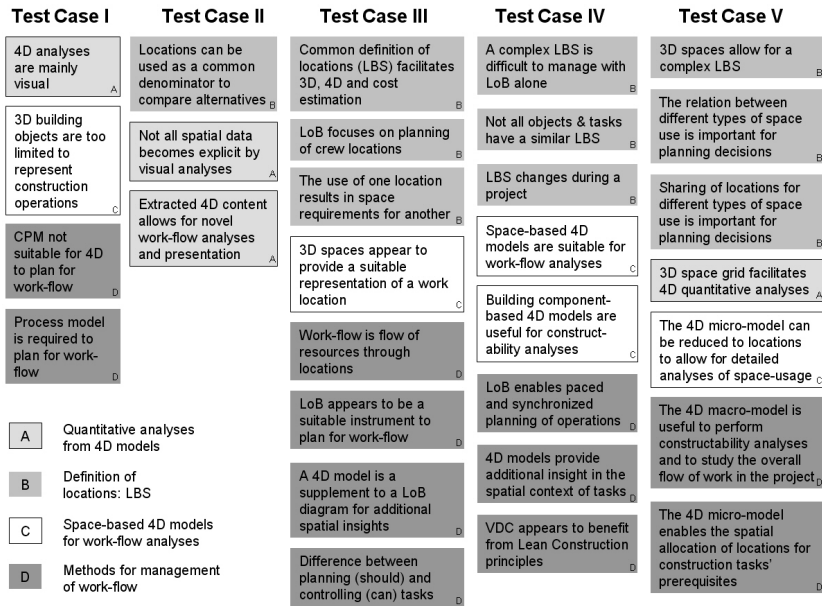

Figure 3.1: Main results from the test cases grouped into four categories: (A) quantitative analyses from 4D models, (B) Definition of locations: LBS, (C) Space-based 4D models for work-flow analyses, and (D) Methods for management of work-flow.

4 CONCLUSIONS, VALIDATION AND DISCUSSIONS

This Ph.D. research presents a novel method for work-flow management in construction. The research addresses three research questions:

- I. What is the practice today to plan and manage the flow of construction work?

The research shows that today's commonly applied methods for project planning provide limited support for the management of the flow of construction work. Today's planning process is mainly focused on organisations and work breakdown, taking the work-flow more or less for granted. Project planning by using the Line-of-Balance method can be an alternative to today's CPM-based practice. The method entails useful mechanisms for the management of work-flow, but does not provide sufficient insight in the spatial configurations of construction tasks.

- II. What is Virtual Design & Construction and how can it support the management of the flow of construction work?

Virtual Design and Construction techniques promote improved understanding of construction operations. 4D CAD, which is a specific Virtual Design and Construction technique, equips planners with a spatial understanding of operations on a construction site, which is not supported by using 2D drawings in combination with CPM schedules or Line-of-Balance diagrams. Most of today's 4D CAD models are based on CPM schedules and are used to communicate the schedule intent on a macro-level in projects. The support for the management of work-flow is limited due to the fact that the models are

based around discrete activities, mainly contain building components and not structured according to a location-based logic.

- III. How can a Virtual Design and Construction-based process model be constructed to support work-flow management of construction work?

Based on the results from research question I and II, I propose a process model that combines the Line-of-Balance technique with 4D CAD. The model considers work-flow of construction work on two levels: a macro- and a micro-level. Scheduling of work-flow on a macro-level provides insight in the overall flow of work through locations on a construction site. The micro-management of work-flow enables the allocation and control of locations for construction tasks' prerequisites.

The use of the Line-of-Balance scheduling technique facilitates the planning for synchronized and paced construction operations, which creates opportunities for construction work to flow unhindered from work-space to work-space. A 4D model provides additional understanding of the context of scheduled construction activities and is on a micro-level of work-flow management an instrument to spatially plan and control the prerequisites for construction tasks.

4.1 Scientific contribution

I have developed a novel process model for the management of work-flow in construction. This is the main scientific contribution of this research, which is also a practical contribution, since the model is based on theory and aimed for use in practice. I have defined the concepts of macro- and micro-management of work-flow. Existing methods for micro-management, such as the Last Planner method, do not explicitly address the spatial properties of construction tasks. The micro-management method that I propose addresses this limitation.

The process model relies on a combination of Line-of-Balance scheduling and 4D CAD. Through my theoretical studies and practical experiments I have identified that the commonly used CPM method is not a suitable method to plan for work-flow in construction. The Line-of-Balance method that I suggest as an alternative to the CPM method provides useful mechanisms to plan for work-flow. However, I have also identified a number of issues that have to be addressed in order to use the method for the management of work-flow (see Test Case V).

Through my work on the test cases I have found that the definition and use of locations on a construction site are important for the planning and control of work-flow, but also for cost estimation and for the comparison of different construction alternatives. I have found that today's WBS is often discipline-oriented and that it provides limited insight in the spatial configuration of construction work. I therefore propose a location-based WBS, which I define as LBS – Location Breakdown Structure.

I have identified reasons (Test Case III) for the limited use of 4D CAD for work-flow management and I suggest two types of 4D models for work-flow management: a 4D macro-model and a 4D micro-model (Test Case V). I define these models as production models. Both models include spaces that facilitate the identification and analyses of work-flow. 4D models can in certain cases be reduced to locations to allow for detailed analyses of space-usage. Especially on a micro-level such locations can be structured according to a grid to facilitate the modelling- and analyses of the 4D model.

Analyses of 4D models are mainly visual and do not take advantage of the quantitative data in 4D models. I have extracted quantitative data from 4D models (i.e. 4D content), which allows for novel presentation and analyses of construction planning information and can possibly be standardized to facilitate the comparative analyses of construction alternatives.

4.2 Practical contribution

I have applied my research work in five case study projects, by which I was able to interact with the research area that I studied. The application of the research work in these cases resulted in dissemination of the proposed process model and an interest among industry professionals to test and apply the research results.

The research work has been the basis for two courses on virtual construction at Luleå University of Technology, in which academic and industry participants from several countries and companies participated. Both courses provided with a rich test ground for the different research ideas and resulted in valuable feedback and validation.

I have made specifications for and participated in the development of software prototypes that I applied to create the different models for my research. These software prototypes are now being used on a commercial basis.

In addition to the publications in scientific journals I have written and presented a number of conference articles and popular-scientific articles. References to these articles are included in the Publication chapter of this thesis.

4.3 Validation and generalization

The research work has been applied to five test cases. Although based on real cases and realistic production data, the specific numeric results of the presented analyses are hypothetical. However, the test cases show a type of reasoning and analyses that does not occur in today's construction planning practice.

Test Case III, IV and V present an application and validation of the proposed process model. The process model was applied on a macro-level in Test Case III, IV and V, and on a micro-level in Test Case V. As a result, compared to the macro-level application in three test cases, I have little test case material to validate the micro-level approach for work-flow management.

In addition, I have personally applied the process model in retrospective test cases that can have limited my ability to objectively observe the results from the test cases, since I knew what I was out after. In Test Case III and IV I have applied the process model in cooperation with others, which I believe has added to the validation and generalization of the research results. Especially the application in courses on virtual construction at Luleå University of Technology has been useful to learn to teach and understand how others can work with my research work.

All the applications in test cases have been based on a limited data set from the industry case projects, mostly for practical reasons. As a result, the validation of my research ideas in test cases is limited in scope and scale, but I believe I have chosen representative datasets from the industry case study projects. The test cases had a different character, which adds to the generalization of the research results. The scale, location, project team and type of construction method were all different in Test Case II – V. From the application one may conclude that the process model is applicable for different types of construction work (e.g. steel, cast-in-place concrete and timber) in projects of different scales.

Test Case II presents examples of quantitative analyses from 4D CAD models. In Test Case V I have repeated one of the analyses as performed in Test Case II. Although the results from Test Case II and V are promising, I believe there

are additional studies required to validate the supposed benefits of quantitative analyses from 4D models and to generalize the performed analyses for construction planning purposes.

4.4 Discussions

4.4.1 General observations

One of the observations that I made in the industry projects that I studied is that planners either plan too much or too little. When the construction work is initiated there is often a plan available with too much detail about construction work that cannot be forecasted with reasonable certainty. As the project progresses this schedule is often only partly updated and not truly followed up upon. As a result, the schedule loses its value. Another observation that I made is that the difference between the schedule and actual state of the construction process is explained away, which makes me wonder whether the work is truly under control. These observations were the main reasons to approach the work-flow management method from a macro- and micro-perspective.

The very activity of planning construction tasks is about looking ahead and about making assumptions. One thing one often can be certain of is that things will turn out differently than planned. My proposed process model does not change this process, since there will always be factors in a construction project that are beyond the control of a project manager. However, the process model provides suitable mechanisms to make a realistic planning and look-ahead schedule, and facilitates the communication of the schedule intent to other project stakeholders. With better informed project participants, including the workers on site, one can avoid many unnecessary surprises that can disrupt or jeopardize construction workers and supplies.

4.4.2 Measuring work-flow

The proposed process model aims to facilitate the management of work-flow and aims thereby to minimize waste in the construction process. One can wonder: what is good work-flow, or what is good-enough work-flow? There is always one thing that one can improve and I therefore believe there is no such thing as the perfect work-flow. Planning for work-flow that is based on a paced and synchronized Line-of-Balance diagram that results in a time-space conflict-free construction process does seem to be a good work-flow. However, this does not necessarily have to be the case, since nothing is known about the

use of resources, duration of the construction process, and about the availability of locations on the construction site. These and many other criteria are all part of the overall level of work-flow efficiency. There are a number of ways by which work-flow could be measured and compared:

- Multiple 4D CAD models can be made for a project, preferably before the construction process is commenced. These models can be analysed visually and quantitatively. Especially quantitative data can provide construction planners with numeric data to establish and compare different work-flow metrics.
- One can measure a number of parameters during a project, from week to week, where one for example compares the availability of work-locations with the use of work-locations, or where one compares the distances between different types of work.
- Projects can be compared to other projects on the aspect of work-flow, using a number of different metrics.

Comparing projects with projects is an actual topic in the Swedish construction industry, since many of the larger construction companies develop their own industrialized building systems. These efforts are aimed at, among other things, taking away some of the uniqueness of construction projects in order to find economies of scale and to be able to improve and standardize specific operations from project to project. I believe this is a positive development, because one needs to have a defined way of doing things in order to be able to improve that way of doing things. The industrialized construction efforts add to achieving this goal.

4.4.3 Industrialization and prefabrication

In many cases the industrialized construction concepts are compared to prefabrication of building components. This is a misunderstanding. Prefabrication is part of an industrialized building concept, but does in itself not guarantee efficient transformations and flow in construction. Building systems, such as prefabricated building structures, are efficient from an assembly perspective. However, these building systems do not guarantee an efficient work-flow, since most of the work-flow disruptions are a result of situations in space and time where different construction trades meet. A building system does not automatically take these points away and needs to be integrated in an overall work-flow planning of trades on the construction site.

4.4.4 Application in the industry

Working with the Line-of-Balance method and 4D CAD models in construction projects have resulted in many positive experiences by project participants and by me. Both techniques improve the visualization of construction planning information dramatically and I wonder why both techniques have not been adopted by the industry more rapidly, which brings me to 'Application in the industry'.

I believe that the proposed process model can improve the management of work-flow in construction projects, but I realize that it is a tool that needs to be applied properly according to a method in a process to be effective. As in any application of new methods and new tools: proper education and additional resources, such as time, are essential. I suggest that the process model is first applied in projects that one is comfortable with, in order to learn the method. In addition, I suggest that the method is first applied on a macro-level in construction projects after which micro-planning aspects are included. As for micro-planning; not all prerequisites for construction tasks have to be controlled by the 4D model when applying the method for the first time(s). Planning spaces for a number of space-critical crews can be a start for the first project in which the method is applied, after which the next prerequisite is included, such as on-site material logistics.

4.5 Suggestions for further research

There are many aspects of my research that can be the basis for further research, and recommendations can be made from different perspectives. One can focus on the tools and technology for work-flow management in construction, but one can also address the methodological, process and organizational aspects. I limit the recommendations to suggestions for further studies on the process model and its applications.

In my research I have considered the Line-of-Balance method as a method to plan for work-flow, but there can possibly exist other methods that provide better mechanisms to plan for work-flow. For example, Akbas (2004) uses 4D models to plan for work-flow and integrates the Line-of-Balance method with 4D models. The geometry-based process method (GPM) actively uses the geometry of the model to model and simulate the work by crews. As noted in the theory chapter, the method is limited to crew-locations, but I believe that my proposed process model could benefit from adapting principles and techniques from GPM.

In addition, I also believe that my proposed process model could benefit from adapting the space use taxonomy by Akinici (2002), to semi-automatically allocate space use for construction tasks and to analyze the relations between them, including the sharing of locations for different types of space use.

The proposed process model is mainly aimed at ensuring an efficient and safe flow of work through locations in projects. I have not explicitly addressed the working environment in my research. However, I believe that my proposed process model can be used to better design and predict the work conditions on a construction site, thereby improving the working environment and minimizing the risk for accidents and work under stress. Thus, I suggest further research on planning for a safe and healthy working environment, based on my proposed process model.

The process model allows users to plan the preconditions for a construction task, but does not address the logistics behind these preconditions, such as the supply chain of materials to and on a construction site. I suggest further studies on how to integrate the work-flow management of a construction site with logistics of the different preconditions for construction tasks. A deeper study on logistics is recommended.

I have referred to industrialized construction in my research and stated that industrialization is not the same as prefabrication. However, prefabrication is an important aspect of industrial construction (Lessing 2006; Olofsson 2004) and can, when properly planned, facilitate the flow of construction work. I suggest further studies on the conditions for industrialized construction using my suggested process model for work-flow management.

The proposed process model relies partly on Virtual Design and Construction techniques and partly on Lean Construction principles. For example, I combine 4D CAD (i.e. a Virtual Design and Construction technique) with aspects of the Last Planner method (i.e. a Lean Construction planning method). I believe that this and other combinations of Virtual Design and Construction with Lean Construction can contribute to the value of the end product and the reduction of waste in the construction process.

References

- Akbas, R. (2004). "Geometry-based modeling and simulation of construction processes," PhD Thesis, Department of Civil and Environmental Engineering, Stanford University, Stanford, USA, 150 pp.
- Akinci, B., Fischer, M., and Kunz, J. (2002). "Automated Generation of Work Spaces Required by Construction Activities." *Journal of Construction Engineering and Management*, 128(4), 10.
- Amor, R. and Faraj, I. (2001). "Misconceptions about integrated project databases." *ITcon Electronic Journal of Information Technology in Construction*, 6, 57-68.
- Andersson, N. and Suber, K. (2006). "Konfigureringsprocessen vid industriellt byggande Förutsättningar för ett framgångsrikt industriellt byggande med fokus på kundanpassning av hus." 2006:33, INDEK, Royal Institute of Technology (KTH), Stockholm.
- Appelqvist, J. (2005). "Location-based scheduling." Presentation at the Virtual Construction course, Luleå University of Technology, Luleå, Sweden.
- Ballard, G. (2006). "Lean Construction." Presentation at Byggkostnadsforum: Från Low-Tech till High-Tech (Forum for Building Costs: From Low-Tech to High-Tech), Stockholm, Sweden, 14 June 2006.
- Ballard, G. (2000). "The Last Planner System of Production Control," PhD Thesis, School of Civil Engineering, Faculty of Engineering, The University of Birmingham, Birmingham, UK, 192 pp.

- Ballard, G., Howell, G. (1998). "Shielding Production: Essential Step in Production Control." *Journal of Construction Engineering and Management*, 124(4), 279-288.
- Bazjanac, V. (2004) "Virtual building environments (VBE) - applying information modeling to buildings." In A. Dikbas, Scherer, R. (eds) *ECPPM 2004 - eWork and eBusiness in Architecture, Engineering and Construction*, Istanbul, Turkey, 41-48.
- Bertelsen, S. (2004). "Lean Construction: Where are we and how to proceed?" *Lean Construction Journal*, 1(1), 46-69.
- Clough, R.H., Sears, G.A., Sears, S.K. (2000). *Construction Project Management, Fourth Edition*, John Wiley & Sons, New York, USA
- Eastman, C.M. (1992). "Modeling of buildings: evolution and concepts." *Automation in Construction*, 1(2), 99-109.
- Ekholm, A., Hågström, L., Tarandi, V., Thåström, O. (2000). "Application of IFC in Sweden - phase 2, working report A15." The Swedish Building Centre, Stockholm, Sweden.
- Fischer, M., and Haddad, Z. (2004a) "A pull-driven project planning and control philosophy and approach." In P. Brandon, Li, H., Shaffii, N., Shen, Q. (eds) *INCITE 2004 - International Conference on Information Technology in Design and Construction*, Langkawi, Malaysia, 23-32.
- Fischer, M., and Kunz, J. (2004b). "The scope and role of information technology in construction." *Technical Report 156*, Center for Integrated Facility Engineering, Stanford University, Stanford, USA, 24 pp.
- Fischer, M., Hartmann, T., Rank, E., Neuberger, F., Schreyer, M., Liston, K., and Kunz, J. (2004c) "Combining different project modelling approaches for effective support of multi-disciplinary engineering tasks." In P. Brandon, Li, H., Shaffii, N., Shen, Q. (eds) *INCITE 2004 - International Conference on Information Technology in Design and Construction*, Langkawi, Malaysia, 167-182.
- Gielingh, W. F. (1989). "General AEC Reference Model (GARM) ISO TC 184/SC4/WG1 Document N329."
- Graphisoft, Inc. (2002). "The Graphisoft Virtual Building: Bringing the Information Model from Concept into Reality - Graphisoft Whitepaper." www.graphisoft.com.

- Graphisoft, Inc. (2006). "Virtual Construction - Graphisoft ArchiCAD, Constructor, Estimator, Control and 5D Presenter." www.graphisoft.com.
- Harris, R.B., Ioannou, P.G. (1998). "Scheduling projects with repeating activities." *Journal of Construction Engineering and Management*, 124(4), 269-278.
- Heesom, D., and Mahdjoubi, L. (2004). "Trends of 4D CAD applications for construction planning." *Construction Management and Economics*, February 2004, 22, 171-182, February 2004(22), 171-182.
- Hendrickson, C. (2000). "Project Management for Construction - Fundamental Concepts for Owners, Engineers, Architects and Builders." <http://www.ce.cmu.edu/pmbook/>.
- Holme, I.M. Solvang, B.K. (1996). "Forskningsmetodik. Om kvalitativa och kvantitativa metoder (Research methodology. Qualitative and quantitative methods)." Lund Tekniska Högskolan, Lund, Sweden.
- Hopp, W. and Spearman, M. (1996). *Factory Physics: Foundations of Manufacturing Management*, Irwin/McGraw-Hill, Boston, USA. 668 pp.
- Huber, B., Reiser, P. (2003) "The Marriage of CPM and Lean Construction." In J. C. Martinez, Formoso, C.T. (eds) *11th International Group for Lean Construction Conference*, Virginia Tech, Blacksburg, Virginia, USA
- IAI. (2006). "International Alliance for Interoperability." <http://www.iai-international.org>.
- Josephson, P-E., Saukkoriipi, L. (2005). "Slöseri i byggprojekt - behov av förändrat synsätt (Waste in construction projects - the need for a different view)." Göteborg, Sweden.
- Karstila, K. (2001). "Industry Foundation Classes IFC - Product models for the AEC industry." Eurostep, Helsinki, Finland.
- Kenley, R. (2004) "Project micromanagement: practical site planning and management of work flow." In S. Bertelsen, Formoso, C.T. (eds) *IGLC-12, 12th Conference of the International Group for Lean Construction*, Helsingor, Denmark, 194-205.
- Koo, B., and Fischer, M. (2000). "Feasibility Study of 4D CAD in Commercial Construction." *Journal of Construction Engineering and Management*, 126(4), 251-260.

- Koskela, L. (1992). "Application of the New Production Philosophy to Construction." *Technical Report 72*, Center for Integrated Facility Engineering, Stanford University, Stanford, USA.
- Koskela, L. (1999) "Management of Production in Construction: A Theoretical View." In I. D. Tommelein, Ballard, G. (eds) *IGLC 7: Proceedings of the Annual Conference of the International Group for Lean Construction*, University of California, Berkeley, CA, USA, 241-252.
- Koskela, L., Howell, G., Ballard, G., and Tommelein, I. (2002). "The foundations of lean construction." *Design and Construction - Building in Value*, R. Best, and De Valence, G., ed., Elsevier Science Ltd., Oxford, UK, 211-226.
- Laitinen, J. (1998). "Model based construction process management," PhD thesis, Royal Institute of Technology (KTH), Stockholm, Sweden, 136 pp.
- Lee, A., Marshall-Ponting, A.j., Aouad, G., Wu, S., Koh, I., Fu, C., Cooper, R., Betts, M., Kagioglou, M., Fischer, M. (2003). "Developing a Vision of nD-Enabled Construction - Construction IT Report." University of Salford, UK.
- Lessing, J. (2006). "Industrialised House-Building," Licentiate Thesis, Department of Construction Sciences, Division of Design Methodology, Lund University, Lund Institute of Technology, Lund, Sweden, 197 pp.
- Li, H., Ma, Z., Shen, Q., and Kong, S. (2003). "Virtual experiment of innovative construction operations." *Automation in Construction*, 12(5), 561-575.
- Mallasi, Z. (2006). "Dynamic quantification and analysis of the construction workspace congestion utilising 4D visualisation." *Automation in Construction*, 15(5), 640-655.
- McKinney, K., and Fischer, M. (1998). "Generating, evaluating and visualizing construction with 4D-CAD." *Automation in Construction*, 7(1998), 433-447.
- Mohr, W.E. (1991). *Project Management and Control, 5th Edition*, Department of Architecture and Building, University of Melbourne, Melbourne, Australia
- Nakagawa, Y. (2005) "Importance of standard operating procedure and visualization to implement lean construction." In R. Kenley (eds) *Proceedings of the 13th Annual Conference of the International Group for Lean Construction*, Sydney, Australia, 207-215.

- NCC. (2006). "NCC Komplet - Industriellt Byggande (NCC Complete - Industrial Construction)." www.ncc.se.
- Olofsson, T., Stehn, L., and Lagerqvist, O. (2004). "Industriellt byggande - Byggbranschens nya patentlösning? (Industrial Construction - The Construction Industry's new Concept?)." *Väg- och Vattenbyggaren*, 19-24.
- Ronen, B. (1992). "The Complete Kit Concept." *International Journal of Production Research*, 30(10), 2457-2466.
- Scania. (2006). "Scania Strategic Platform." www.scania.com/about/platform/.
- Seppänen, O., Kankainen, J. (2004) "Empirical research on deviations in production and current state of project control." In S. Bertelsen, Formoso, C.T. (eds) *IGLC-12, 12th Conference of the International Group for Lean Construction*, Helsingor, Denmark, 206-219.
- SOU. (2000). "Betänkandet från Byggsekt till Byggsektor (considerations for transition from construction sect to construction sector)." *SOU 2000:44*, Finansdepartementet, Stockholm, Sweden.
- SOU. (2002). "Skärpning gubbar! Om konkurrensen, kostnaderna, kvaliteten och kompetensen i byggsektorn (Wake up fellows! About competition, costs, quality and skills in the construction sector)." *SOU 2002:115*, Miljö- och samhällsbyggnadsdep. Bygghögskolan, Stockholm, Sweden.
- Tanyer, A.M., Aouad, G. (2005). "Moving beyond the fourth dimension with an IFC-based single project database." *Automation in Construction*, 14(1), 15-32.
- Toolanen, B. (2006). "Lean Construction - samverkansinriktat industriellt processtänkande (Lean Construction - a cooperation-oriented industrial process approach)." *Väg- och Vattenbyggaren*.
- Woksepp, S., Jongeling, R., and Olofsson, T. (2005) "Applying Virtual Reality and 4D CAD models in the scheduling process of a large pelletizing plant." In N. Dawood (eds) *CONVR - Conference on Construction Applications of Virtual Reality*, Durham, England
- Womack, J.P., Jones, D.T., Roos, D. (1990). *The Machine that changed the World*, Rawson Associates, Simon & Schuster, New York, USA. 323 pp.

Publications

Appended papers

The following journal articles are appended to this thesis:

Paper I

Jongeling R, Emborg M and Olofsson T (2005) “nD modelling in the development of cast in place concrete structures”, *ITcon Vol. 10, Special Issue From 3D to nD modelling*, 27-41, <http://www.itcon.org/2005/4>

Paper II

Jongeling, R., Kim, J., Mourgues, C., Fischer, M., Olofsson T. (2006) “Quantitative Analyses Using 4D Models - An Explorative Study”, *Submitted to Automation in Construction, Special Issue on Digital Construction (September 2006)*

Paper III

Jongeling, R., Olofsson, T. (2006) “A method for planning of work-flow by combined use of location-based scheduling and 4D CAD.” *Automation in Construction (article in press)*

Paper IV

Björmfot, A., Jongeling, R. (2006) “Application of Line-of-Balance and 4D CAD for Lean Planning.” *Accepted for publication in Construction Innovation (July 2006)*

Paper V

Jongeling, R., Olofsson, T. (2006). "A method for macro- and micro-management of work-flow by combined use of location-based scheduling and 4D CAD." *Submitted to Computer-Aided Civil and Infrastructure Engineering (March 2006)*

Conference articles

During my research I presented and published my work on a number of conferences and in a number of technical reports and popular-scientific articles.

Jongeling, R., Olofsson, T. (2006) "A combination of 4D modelling and location-based scheduling to support work flow management in the construction process of a pelletizing plant." *INCITE – ITSED 2006 World Conference on IT*, New Delhi, India.

Jongeling, R., Kim, J., Mourgues, C., Fischer, M., Olofsson T. (2005) "Quantitative Analysis Using 4D Models - An Explorative Study." In C. Park (eds) *First International Conference on Construction Engineering and Management*, Seoul, Korea.

Woksepp, S., Jongeling, R., and Olofsson, T. (2005) "Applying Virtual Reality and 4D CAD models in the scheduling process of a large pelletizing plant." In N. Dawood (eds) *CONVR - Conference on Construction Applications of Virtual Reality*, Durham, England.

Woksepp, S., Olofsson, T. and Jongeling, R. (2005) "Design reviews and decision-making using collaborative virtual reality prototypes; a case study of the large-scale MK3 project." *Proceedings of the 13th Annual Conference of the Int. Group for Lean Construction*, Sydney, Australia, 19-21 July 2005, pp. 145-152.

Jongeling, R., Olofsson, T., and Emborg, M. (2004) "Modelling cast in place concrete construction alternatives with 4D CAD." In A. Dikbas, Scherer, R. (eds) *ECPPM 2004 - eWork and eBusiness in Architecture, Engineering and Construction*, Istanbul, Turkey, 109-116.

Blokpoel, S., Olofsson, T., and Jongeling, R. (2004) "Cooperation and product modelling systems." In A. Dikbas, Scherer, R. (eds) *ECPPM 2004 - eWork and eBusiness in Architecture, Engineering and Construction*, Istanbul, Turkey, 423-429.

Jongeling, R., Olofsson, T., and Emborg, M. (2004) "Product modelling for industrialized cast-in-place concrete structures." In P. Brandon, Li, H., Shaffii, N., Shen, Q. (eds) *INCITE 2004 - International Conference on Information Technology in Design and Construction*, Langkawi, Malaysia, 103-110.

Articles and Reports

Jongeling, R. (2006) "Planering av arbetsflöde med 4D-modeller och Line-of-Balance." (Planning of work-flow with 4D models and Line-of-Balance), *Bygga Framtid – tidskrift samhällsbyggnad Luleå Tekniska Universitet*, 17

Jongeling, R., Emborg, E., Asp, M., and Olofsson, T. (2005) "Modelling and Simulations of Cast in Place Concrete Construction Using N-Dimensions." Research Report 2005:18, Department of Civil and Mining Engineering, Luleå University of Technology, Luleå, Sweden

Jongeling, R. (2005) "Nya planeringsverktyg för effektivt betongbyggande." (New scheduling applications for efficient concrete construction) *Bygg & Teknik*, 7/05, 15-171

Jongeling, R. (2004). "IT-stomme - produktmodeller i stombyggnadsprocesser." (IT-Structure – product models for building structures) *Betong - Svenska Betongföreningens Tidskrift*, 4, 40-42

Emborg, M. and Jongeling, R. (2004) "Produktmodeller för platsgjuten betong." (Product models for cast-in-place concrete) Technical Report 2004:01, Department of Civil and Mining Engineering, Luleå University of Technology, Luleå, Sweden

Jongeling, R. in Eriksson, L. (2003) "3D pressar priset på bygget." (3D reduces construction costs) *Ny Teknik*, 2003:6

Jongeling, R. (2003). "Product modelling for cast in place concrete – a feasibility study." Technical Report 2003:01, Department of Civil and Mining Engineering, Luleå University of Technology, Luleå, Sweden.

nD MODELLING IN THE DEVELOPMENT OF CAST IN PLACE CONCRETE STRUCTURES

SUBMITTED: October 2004

REVISED: February 2005

PUBLISHED: April 2005 at <http://www.itcon.org/2005/04/>

EDITORS: G. Aound, A. Lee and S. Wu

Rogier Jongeling, PhD Student

*eBygg – Center for Information Technology in Construction, Department of Civil & Environmental Engineering, Luleå University of Technology, Sweden
email: rogier.jongeling@ltu.se, <http://ebygg.ce.luth.se>*

Mats Emborg, Professor

*Head of Research and Development, Betongindustri AB, Stockholm, Sweden and, Department of Civil & Environmental Engineering, Luleå University of Technology, Sweden
email: mats.emborg@betongindustri.se, <http://www.betongindustri.se>*

Thomas Olofsson, Professor

*eBygg – Center for Information Technology in Construction, Department of Civil & Environmental Engineering, Luleå University of Technology, Sweden
email: thomas.olofsson@ltu.se, <http://www.cee.ltu.se>*

SUMMARY: *The Swedish IT-stomme (IT-structure) project is a two year research project, which is aimed at applying product models in practice and developing modelling tools for cast in place concrete structures. Implementations and applications discussed in this paper are mainly driven by the interests from a ready mixed concrete supplier who identified product modelling as a threat and as an opportunity for its business process. A number of product model dimensions is discussed that result from combining different software applications. An example of a potential n^{th} dimension of product model development and use is given, in addition to a product model's 2nd, 3rd, 4th and 5th dimension. The n^{th} dimension is illustrated by integrating a product model with results from a program used to calculate the optimal drying process for concrete slabs. This paper concludes by discussing main challenges for the uptake of product models in practice in relation to findings and efforts from the IT-stomme project.*

KEYWORDS: *product modelling, cast in place concrete, nD*

1. INTRODUCTION

The Swedish IT-stomme (IT-structure) project is a two year research project, which is aimed at applying product models in practice and developing modelling tools for cast in place concrete structures. The project was initiated in September 2003 by Luleå University of Technology and aims to establish routines for design, estimation and planning in a product modelling environment.

In this paper we discuss the research and development work on the issues of integration of different model dimensions among different actors in the IT-stomme project. The main actors in the project are Betongindustri, a ready mixed concrete supplier, and JM which is a residential project developer. In a joint feasibility study it was shown that product modelling has the potential to improve the business process as well as the information management and cooperation in projects between Betongindustri and JM (Jongeling 2003). As a result, both companies joined the IT-stomme project to study the application of product models in a real construction project.

The definition and interpretation of product modelling are first discussed. Secondly, the concrete supplier's motivation to study product modelling is analysed after which the product modelling system used in the IT-stomme project is presented. Thirdly, the different model dimensions of product modelling are presented, illustrated by examples from a case study project. Finally, the result of the study on the different model dimensions are analysed and discussed. This paper does not discuss the structural design of concrete structures

with product modelling systems, but focuses on the use of product models throughout a building process from the perspective of a ready mixed concrete supplier.

2. PRODUCT MODELLING

The development and use of computer-based models for the AEC (Architecture, Engineering and Construction) industry has been discussed within international research and development communities for some time (Eastman 1992; Fischer 2004b; Gielingh 1989; Laitinen 1998). Different terms and concepts are used in discussions to denote these models and modelling systems. Recently, the concepts of a building information model (BIM), nD modelling and virtual building environment (VBE) have been added to the terminology describing information models for the AEC industry.

BIM was launched by major vendors of CAD applications such as Autodesk, Graphisoft, Bentley and Nemetschek. A BIM is a computer model database of building design information, which may also contain information about the building's construction, management, operations and maintenance (Graphisoft 2002). Research and development regarding nD modelling is currently mainly conducted at the University of Salford within the 3D to nD modelling research project (Lee 2004). An nD model is an extension of the BIM, which incorporates multi-aspects of design information required at each stage of the lifecycle of a building facility (Lee 2003). A Virtual Building Environment (VBE) is a "place" where building industry project staffs can get help in creating BIMs and in the use of virtual buildings (Bazjanac 2004). A virtual building is a BIM, or an nD model, deployed in software. VBE consists of a group of industry software that is operated by industry experts who are also experts in the use of that software (Bazjanac 2004).

Throughout this paper we use the following terminology:

- A product model refers to data models that contain both product and process data supporting a building's life cycle. Examples of such data are geometry, planning and cost data. According to this definition we define BIMs and nD models as product models.
- Product modelling systems are used to access, manipulate and store information from exchange files and databases. Examples of such systems are CAD applications, but also project planning software and product model servers.
- We define the collection of product modelling systems used in a project, including the professionals that operate the systems, as the product modelling environment. We define VBEs as product modelling environments.

Although definitions of product models and nomenclature vary within the research and development communities, most actors agree that the main advantage of product models lies in tasks beyond 3D modelling and generation of drawings for a building (Fischer 2004b). Within the IT-stomme project a client-server modelling system has been developed and applied in a case study. Before we describe the product modelling system used in the case study, the motivation of the cast in place concrete industry to adapt product modelling and to develop product modelling systems is discussed next.

3. MOTIVATION: PRODUCT MODELLING FOR CAST IN PLACE CONCRETE

There is an increasing interest of the Swedish cast in place concrete industry in product modelling technology. The steel and prefabricated concrete industries have already started to use a model-based construction approach. The main product modelling system developments and standardization efforts to date have focused on these sectors. This focus can partly be explained by the nature of the building technology. Steel and prefabricated concrete are strongly component oriented in both design and production as opposed to the design and production process of cast in place concrete structures. Product modelling systems imply an object oriented approach and are therefore well-suited for object oriented building systems based on steel and prefabricated concrete components.

One of the strengths of cast in place concrete is customisation of shapes and material properties. Basically any shape can be created by forming the concrete on site in tailor-made forms. The customisation and freedom of design partly explain the absence of standard product catalogues for cast in place concrete objects. However, the main reason for this absence is the fact that the product is a material and not a building object. Standard product libraries that are available in CAD applications for steel and prefabricated concrete objects do not exist for the

cast in place concrete industry. There is in other words no explicit integration of the design object and supplied product in CAD systems for cast in place concrete.

In addition to difficulties with product specification and design in CAD systems there is no single definition of an object. Design objects differ from production objects of which the latter is often not explicitly modelled. An example of a production object is a concrete pour. The design is used as a bounding box for production solutions, as opposed to steel construction where design information is used to direct production by Computer Numerical Control (CNC). Most of today's product models do not contain objects that are suitable for detailed construction simulation and optimisation of cast in place concrete structures.

Cast in place concrete construction is information intensive. Object properties such as concrete quality and water to cement ratio are continuously updated depending on changes in production planning and weather conditions. This information is in our experience currently not integrated or associated with production models by concrete suppliers. The number of possibilities and limitations that we have identified from the reasoning above are summarized in TABLE 1.

TABLE 1: Possibilities and limitations in use of product models for cast in place concrete from the perspective of a concrete supplier

Possibilities	Limitations / Constraints
Simulation of innovative products and production processes.	Design objects differ from production objects.
Material specifications integrated in product models.	Limited support in CAD applications for modelling of cast in place concrete objects.
Product models linked and associate with data, such as results of technical calculations.	Material specifications are often not linked to or specified in product models

These possibilities and limitations serve as a starting point to formulate a number of improvements in product modelling environments for the cast in place concrete industry. Before these developments and applications are discussed, we will introduce the product modelling environment applied in the case study of the IT-stomme project.

4. PRODUCT MODELLING ENVIRONMENT

A residential construction project is modelled in the IT-stomme project with an Internet-based product modelling system developed by Enterprixe Software Limited (Enterprixe 2002). The system uses a central database in which the product model is stored. Additional databases containing for example cost data or documents can be linked to the central database, Fig.1.

When logged in, a project can be selected from the product model server and specific client software to view and edit the product model. AutoCAD-based software and a VRML viewer embedded in an Internet browser are used as software clients to the product model server in the IT-stomme project. Many actors are already familiar with AutoCAD in Sweden and the transition to a model-based practice using AutoCAD as an interface facilitates this process.

Exchange file import and export is used in addition to direct client-server connection to extend the product modelling environment. For example, IFC files are imported from ArchiCAD to AutoCAD Architectural Desktop (ADT), which in its turn is a client to the product model server. Industry Foundation Classes (IFC) is a product model data standard developed by the International Alliance for Interoperability (IAI) (IAI 2004). IFC objects are uploaded from ADT to the central database, where they become available for all project participants.

check out a valuable product model server functionality that reduces the risk for double work and product model inconsistency.

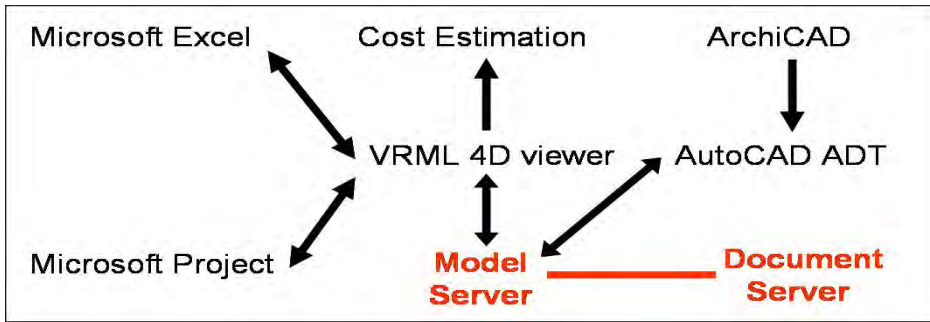

FIG. 1: The product modelling environment of the IT-stomme project. The model server and document server are two different systems, but have been integrated in the IT-stomme project and act as one system. Different software systems can be used to create, edit and use product model data. Examples of these systems are AutoCAD, Microsoft Excel, Microsoft Project and a VRML 4D model viewer.

The product model is loaded from the product model server to local computers and constantly updated when connected to the server. The case study product model contains approximately 3000 objects. It is possible to load or unload parts of the product model. The product model server keeps track of users who create an element or who edit one. Fig2. illustrates the partial model check out and check in functionality. Product model objects that are checked in appear as normal elements. Elements that are checked out by the current user carry a check-mark (☑). Checked out elements are locked for editing by other users. Elements checked out by other users, cross-marked (☒), are locked and cannot be edited. Modelling work is concurrently carried out by multiple co-located users within the IT-stomme project. Project participants consider the partial product model check in and

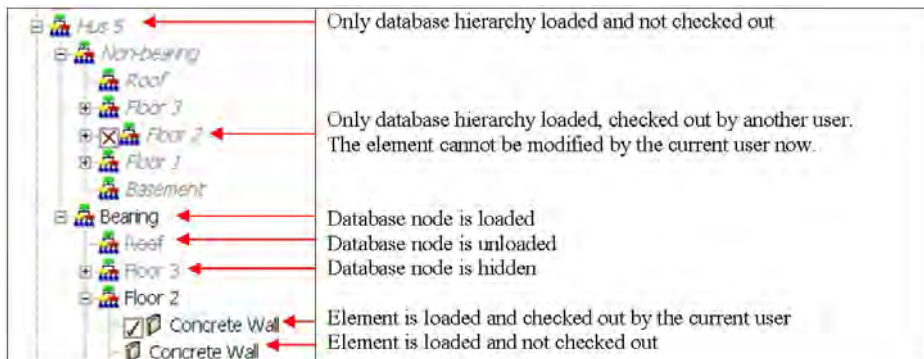

FIG. 2: A tree view of the product model at the product model server. Partial product model check in and check out functionality is used to reduce the risk for double work and product model inconsistency.

5. CASE STUDY

To illustrate the use of product models for cast in place concrete, a “real world” test case is used: the Hotellviken project, which is developed and built by JM. The project comprises the construction of 120 apartments of which the first phase is addressed in this paper. Phase one consists of five multi-storey apartment blocks (in total 25 apartments) of which two are connected with a parking garage.

FIG. 3 shows a 3D model of the concrete structure. The bearing structures are cast in place concrete. Facades consist of standardized non-bearing prefabricated plastered elements. Prefabricated lattice girder elements are used for slabs on which cast in place concrete is poured. Traditional formwork is used for the inner walls in which concrete is poured on site.

The Hotellviken project is ongoing during the IT-stomme project and is modelled in parallel to the traditional 2D paper-based design and construction process. Hotellviken is used to study and develop the following product model applications:

- Traditional 2D drawings and documents are partly generated from 3D models and hyperlinked to these models.
- Various types of 3D models from different disciplines are created by using file-based data transfers and a collaborative client-server environment.
- Multiple production plannings are linked to 3D models resulting in 4D models.
- 3D models are mapped to cost estimation hierarchies providing a 5th dimension.
- Model use and configuration by the ready mixed concrete supplier provides an additional dimension.

These product model applications are discussed in the following section and illustrate the use of a product model beyond 3D graphics.

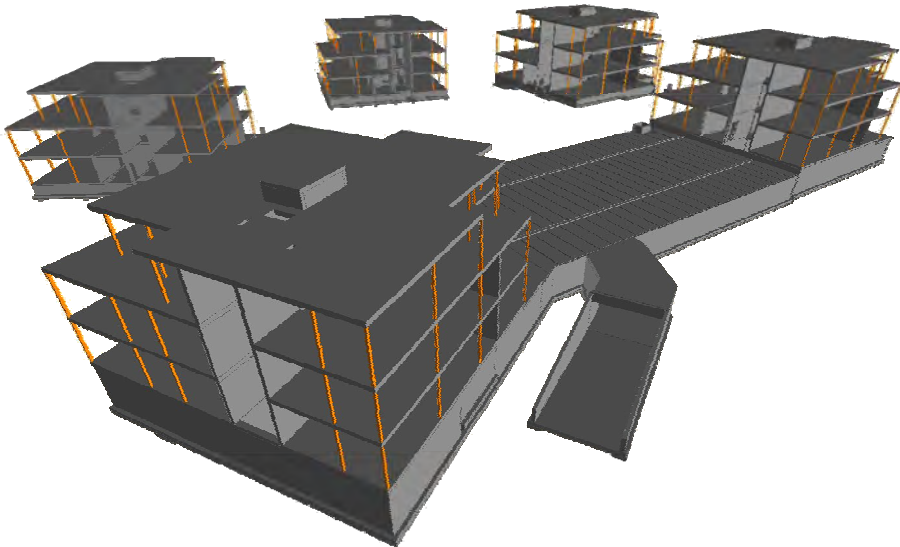

FIG. 3: Bearing structure of the Hotellviken project.

6. FROM 2D TO 3D

Researchers (Lee 2004) and software developers (Autodesk 2002; Graphisoft 2002) envision a database constructed with intelligent objects from which different views of the information can be generated automatically; views that correspond to traditional design documents such as plans, sections, elevations, schedules, et cetera. As the documents are derived from the same central database, they are all coordinated and accurate.

We identify a number of issues that currently limit the use of product models to the extent envisioned in the above:

- First of all, generating views from product models is currently partly possible. Product models do not necessarily contain all information that is required to produce design views. Absence of information is due to unavailability of adequate modelling tools, required effort to add this information to product models and the effort to extract the information. For example, modelling work of certain reinforcement bars is possible in a limited number of CAD systems. Generating views from these systems is constrained by national and local preferences of reinforcement bar detailing in shop drawings.

- Secondly, views of product models differ between actors. For example, a structural engineer models building objects differently from objects modelled by an architect, Fig.4 A. Generating specific views from a multi-disciplinary central model that contains all information is constrained by these different views.
- Thirdly, certain information is associated with a model, but not necessarily part of a model. Even in the most optimistic scenario for model-based approaches, the vast majority of current project information exists in the form of unstructured documents (Froese 2004b). At present there is very little linkage between information technologies for working with unstructured document-based technologies and model-based technologies.
- Finally, the number of actors in a construction project that can access and operate software tools to generate database views is mostly limited to actual product modellers. In addition to modellers we see a number of actors that are merely viewers of product models, such as estimators, planners, suppliers, subcontractors, customers, et cetera. These actors do not necessarily have product modelling systems installed and lack the knowledge to generate specific views from a product model.

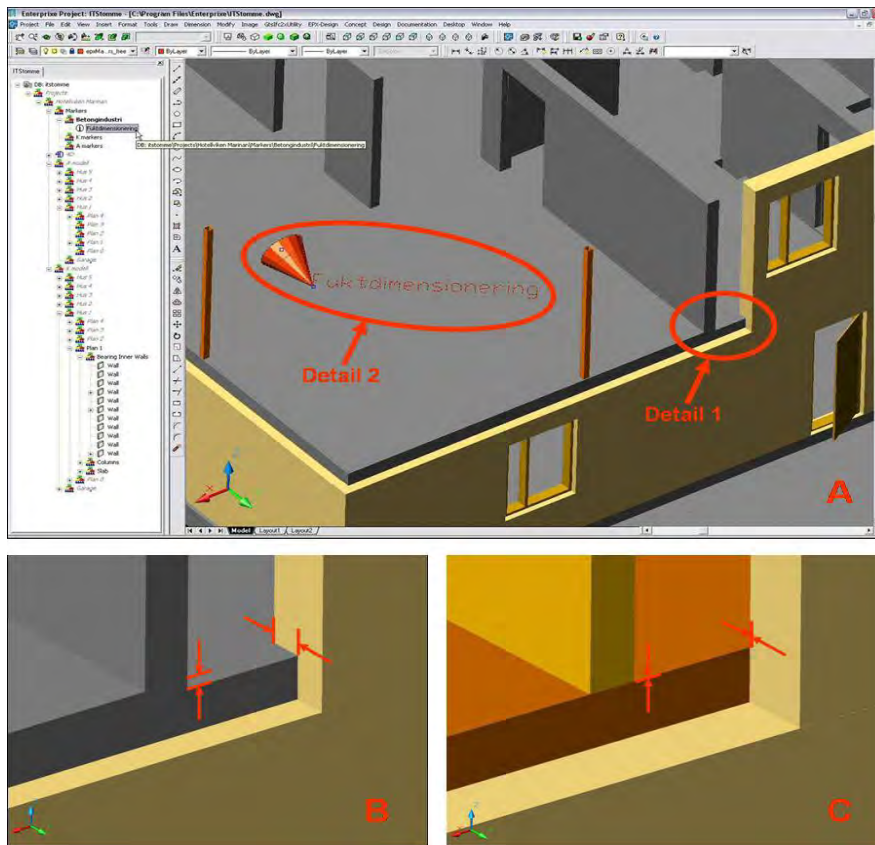

FIG. 4: (A) A product model in AutoCAD ADT connected to the Enterprixe product model server. Detail 1 illustrates different views on modelling by a structural engineer (B) and an architect (C). The architect modelled the slab as one volume, whereas the structural engineer modelled different concrete slabs individually. (A) Detail 2 is an example of pointer object for a concrete slab to which results from technical calculations are linked, which are located at a document sever.

The following solutions were applied in the IT-stomme project to combine 2D data with product models and to make this data and product models available for all project participants:

- Separate architectural and structural models were created of Hotellviken instead of an all-including single product model. All other design, such as building services design, was done according to a traditional 2D practice. The architectural model was modelled in ArchiCAD and exported as an IFC2x file to AutoCAD ADT. The IFC2x file was uploaded from AutoCAD ADT to the central database where it became available for all project participants. The structural model was modelled in AutoCAD ADT, used as client-software to the central database.
- Views were generated from 3D models to which 2D geometric primitives were added in paper space. We call this a hybrid design document type. The views were saved at the model server and could automatically be updated with product model data when required. 2D data, such as reinforcement bar detailing, could only manually be updated per view.
- Product model views and other documents were located at a document server and were hyperlinked to the product model. Links were added to specific model objects, but also to parts of an object or to specific sections of a product model. For this purpose different types of pointer objects were used in the model that contained links to the document server. Different pointer objects were available for different disciplines to facilitate information management, Fig. 4 A.
- A VRML model viewer was used as client software to view the product model in the central database and to browse through hyperlinked data.

6.1 Analysis

Working with two separate product models proved to be beneficial, but also showed limitations. An advantage of a separate product model per design discipline was that both the architect and structural engineer could have their own view on their design practice, which they were familiar with. Legal concerns by project participants were minimized with this approach, which facilitated the acceptance and uptake of 3D modelling. A disadvantage of this approach was the lack of coordination between different models. Updates in the architectural model that affected the structural model had to be propagated manually in the structural model. Product model clash detection software (Commonpoint 2004; Navisworks 2004) or model checking software (Solibri 2004) was not used in the IT-stomme project, but could have saved time and increased the accuracy in the process of coordination product models from different disciplines.

The process of generating views from 3D models and adding 2D data proved to be feasible for the Hotellviken project. Difficulties were experienced when updates were made in the central product model. Ensuring up-to-date 2D data in all separate model views of for example reinforcement bars was a process that did not provide significant advantages compared to the traditional 2D structural design process.

Project actors that did not have CAD software installed could view and browse the product model with inexpensive viewing clients. To illustrate: at the start of the IT-stomme project there was one CAD system available at JM and one at Betongindustri. No experienced CAD personnel was available to operate CAD systems as product model server clients in the two organizations. Using Internet explorer-based product model viewers facilitated the uptake of product model use in both organisations. Model views and other documents, located at a document server, became centrally available by using product model viewers. Using the 3D model was believed to add to project participants' understanding of to what part of the model the different documents and views were related.

It became clear during the project that there was a need for a central person that would coordinate and ensure proper linking of the product model with information located elsewhere. A number of other tasks and responsibilities were identified, in addition to management of linked information to the product model. Examples of these tasks and responsibilities are:

- Management of the product model server
- Coordinating and ensuring the use of templates for modelling work
- Integration of product models from different disciplines
- Education and knowledge management of (potential) model users

Research efforts by Froese on the integration of product models with document-based information (Froese 2004b) and on the definition of a Project Information Officer (PIO) (Froese 2004a) can be mentioned here as potential future developments that are relevant to integration and management of product models with 2D data.

7. FROM 3D TO 4D

Architectural and structural models served as a basis for 4D modelling and simulation. 4D modelling is an increasingly used process method in which 3D CAD models are visualized in a 4-dimensional environment. A currently widely used method for process modelling is the Critical Path Method (CPM). The method concentrates mainly on the temporal aspect of construction planning and is seen as one-dimensional (Heesom 2004). Construction projects have unique spatial configurations and the spatial nature of projects is very important for planning decisions (Akbas 2004). CPM schedules do not provide any information pertaining to the spatial context of project components and requires users to look at 2D drawings to conceptually associate components with the related activities (Koo 2000; Koo 2003). This approach limits evaluation and comparison of alternative solutions. Construction plans can be represented graphically by adding the time dimension to 3D models to allow project planners to simulate and analyze what-if scenarios before commencing work execution on site (Mallasi 2002). 4D modelling is identified as a tool to convey planning information (visualization tool), enhance collaboration among project participants (integration tool), and to support users to conduct additional analyses (analysis tool) (Koo 2000).

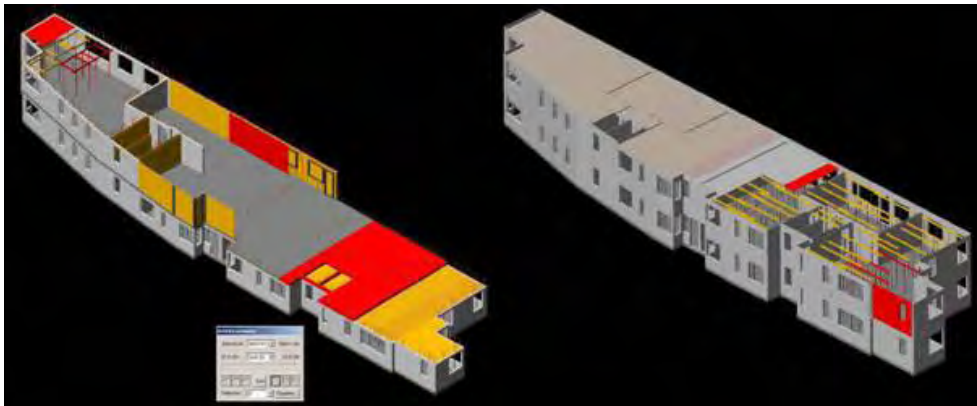

FIG. 5: Parallel simulation and comparison of construction alternatives in 4D CAD. (Left) Traditional production technology. (Right) Industrialized practice combining innovative technologies, such as permanent formwork systems, reinforcement carpets and self-compacting concrete. Colour settings in simulations: Red = in activity, grey = finished elements, yellow = traditional formwork and shoring elements

Within the IT-stomme project 4D CAD was used as an instrument to introduce construction innovations and to evaluate construction alternatives for cast in place concrete construction. Two alternative models were created of a project similar to Hotellviken in order to compare different construction methods (Jongeling 2004b), FIG. 5. The first alternative, the 0-Reference scenario, represented today's common practice for cast in place concrete construction. The objective of this scenario was to represent typical sequenced and concurrent activities on a construction site that are related to casting of concrete walls and slabs. The second alternative provided an industrialized approach to cast in place concrete construction. A number of innovative production technologies formed the basis for this alternative. The objective was to visualize the potential for permanent formwork systems in combination with the use of prefabricated carpets of reinforcement and self-compacting concrete. Such a combination of innovative production technologies had not been applied in actual projects in Sweden and the possibility to evaluate these methods in a virtual environment was considered to be useful.

Production models were created, in addition to architectural and structural models, to suit detailed production simulation of both construction alternatives. CPM schedules were imported to the database and linked to

production model objects. The architectural model and structural model were too abstract to be used for specific construction operations. In order to create production models from architectural and structural models:

- Changes were made in the 3D CAD object hierarchy. 3D CAD objects were regrouped to represented work packages and activities
- Certain objects had to be split and regrouped. This especially applied to large objects, such as slabs
- 3D CAD objects were added that were not present in the architectural model. As an example traditional formwork can be given. The objects solely served a visual purpose and were abstract representations of actual formwork elements

7.1 Analysis

Both construction alternatives were simulated in parallel in 4D CAD. A number of time-space conflicts was detected during the 4D modelling process, that had not been detected in the CPM schedule. Parallel visualization was considered effective to visually explain the differences between the two construction alternatives. The simulations were evaluated by a number of professionals and it was generally agreed that the 4D models helped to understand the different construction processes, but it was noted that the models were limited in scope and non-interactive. The client-server product modelling system was considered too slow and too unstable for presentation of 4D model results in project meetings and at seminars. Standard construction sequences were therefore recorded in AVI-format, limiting the interaction with the models.

Evaluation of alternative work flow strategies or changes in productivity could not easily be managed in the 4D models. The 3D CAD objects in the production models that had been created and grouped to represent specific activities, i.e. formwork, reinforcement and concreting, constrained the rapid evaluations of alternatives. Changes in the architectural and structural model and changes in the schedule implied often major changes in the production model. The detailed production models required considerable modelling effort and were due to their complexity and interdependencies difficult to manage. The complexity of the CPM schedules that contained a large number of dependencies between activities further constrained the management of the production models. Akbas (2004) notes that when models accurately represent construction operations, the model complexity increases significantly and consequently the effort to create and maintain these process models.

We consider a number of developments that can possibly address the issues related to the creation and maintenance of 4D CAD production models (Jongeling 2004b):

- Akbas (2004) proposes a geometry-based process model (GPM). The use of geometry in this approach is not limited to visualization, but is integrally used to model and simulate processes. 4D input models are decomposed into sub-systems. Every sub-system contains crew parameters, geometric work locations and interactions. The approach then reduces this process model into queuing networks and uses discrete event simulation to simulate construction operations. Each of these steps uses geometric techniques, such as triangle meshes and geometry sorting. Applying GPM to the comparison of construction alternatives in this study could possibly have reduced the modelling work related to splitting 3D CAD objects into production objects of appropriate size. GPM could also have reduced the level of detail of both the CPM schedules and 3D models, and could have facilitated the planning of work flow directions.
- Adding CAD objects to represent for example temporary structures, such as traditional formwork elements, could be partly automated by using feature-based 4D models. Feature modelling is an approach whereby modelling entities termed features are utilized to provide improvements for common geometric modelling techniques (Kim 2004, unpubl.). The application of feature-based 4D models could possibly have reduced the modelling work for the 4D simulations and could have contributed to the quality of the temporary structures plans.
- Although 4D simulations are a promising method to evaluate complex schedules, the method still relies on CPM schedules. As noted in the above, CPM schedules do not provide information about the spatial context of production processes. An additional shortcoming of CPM is the difficulty of identifying work flow in a production system. Research initiatives within the Lean Construction Institute (LCI 2004) on the development and application of Line-of-Balance scheduling techniques (Kenley 2004) can possibly provide an alternative for or addition to CPM based scheduling for 4D CAD.

As a future extension of the IT-stomme project and conducted 4D simulations, we plan a number of simulations with developed GPM prototype software. In addition to experiments with GPM, we plan a study to evaluate feature-based 4D models and integration of Line-of-Balance planning software (DSS 2004) with 4D CAD.

8. FROM 3D TO 5D AND BEYOND

In addition to the 2nd, 3rd and 4th dimension, we studied and developed integration of product models with cost data to facilitate the cost estimation process. This process is referred to as 5D modelling (Edgar 2002). Currently the quantity take off is done manually from paper drawings, which is time consuming and prone to errors.

The cost estimation process with the use of product models was not as straightforward as multiplying model object quantities with unit costs. Certain product model objects were abstract representations of object assemblies that required mapping of cost and resource recipes with product model objects. For this purpose, a separate estimation hierarchy was created in the database that was mapped to model objects from the architectural and structural object hierarchies. The process of mapping included the creation of an estimation hierarchy to which product model objects were linked. The estimation hierarchy was created according to a Swedish estimation process standard. Standardized model-based estimation files were exported from the product model server to cost estimation software. Data from the product model was mapped in the estimation software with recipes from JM's cost and resource database, resulting in cost estimates and a preliminary production planning. Recipes in the database contained the approximate amount of resources and materials needed for the construction of model objects.

By using standardized object types and recipes one can enhance standardization of products and processes, and can semi-automatically generate a 4th dimension (Jongeling 2004a). However, cast in place concrete is not a single standard product and has no standard process. The products and processes are to a certain extent standard, but can require customization of for example material properties. With standard recipes for cast in place concrete one can only use known product and process information resulting in solutions not adapted to the actual construction site. There is a risk that models will contain generic information from for example cost estimation databases that is not tailored and checked by specialists. Input to product models from expert systems used by a supplier to calculate material properties can be an example of the configuration of a product model by specialists and illustrates an nth dimension of product model use.

8.1 nth dimension

Within the IT-stomme project we illustrated a product model's nth dimension by using a program called TorkaS. TorkaS served as a typical example for the integration of product data into a product model. The program is used to calculate the optimal drying process of concrete slabs. The drying time of slabs often proves to be a bottleneck in projects, leading to costly delays. Slabs have to have reached a relative humidity of 85% before they can be covered by other floor material. A relative humidity higher than 85% can result in moisture damage, such as mould, which is negatively affecting the indoor climate of a building (Hedenblad 1996).

The output of TorkaS consists of time frames for the drying process of slabs and material properties, such as specific concrete classes and Water to Cement ratios, Fig.6. The material properties, determining the drying process, were configured in the product model of Hotellviken by using VRML clients to the central product model server. The time frames were integrated in the construction planning and linked to the product model. The model was browsed in 4D, using the VRML model viewers. Standardized property reports, including product data specifications, were linked to slabs in the product model via pointer objects, Fig.4 A, in addition to configured slab properties and 4D simulations.

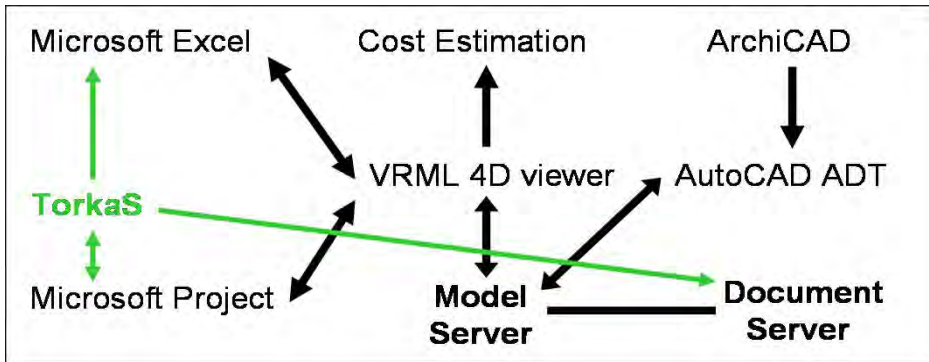

FIG. 6: TorkaS, a program to calculate the optimal drying process of concrete slabs, is used as an example of the integration of product data into a product model. The output from the TorkaS program is used to configure product model object properties, using Microsoft Excel. Planning data from TorkaS is used in Microsoft Project, which is linked to the product model and used for 4D simulations. Calculation reports from TorkaS are located at a document server and linked to the product model.

8.2 Analysis

The 5th dimension to product modelling has been demonstrated in a number of research initiatives (Edgar 2002; Kam 2002; Laitinen 1998) and is already commercially applied. As a result, 5D implementation in the IT-stomme project was a proof of concept for the project participants. A number of companies currently emerges in Sweden that provide cost estimation services based on product modelling for project developers and construction companies. These companies use product models for a variety of analyses in addition to 5D modelling, such as energy simulation, lighting, accessibility, et cetera. Creating a product model solely for estimation purposes is considered a viable business case for these companies. Additional analyses that can be performed with product models add to the value of the models.

The relevance of configuring product model contents by a ready mixed concrete supplier was illustrated by using an expert program for calculation of concrete slab properties. The resulting model properties and 4D simulations that follow from this process are an example of a potential business case for the ready mixed concrete supplier.

9. DISCUSSION AND RECOMMENDATIONS

The objective of the IT-stomme study was to illustrate and develop the use of product models in practice beyond 3D modelling. Despite the possibilities of different model dimensions reported in this paper, the uptake is slow and the comprehensive use is poor. Most of the modelling and coordination work was performed by a few individuals outside the core project team of Hotellviken. Motivating participating companies to commit resources for product modelling in future projects is hard due to difficulties in explicitly communicating benefits from model development and applications in the Hotellviken project.

Difficulties in explicitly demonstrating the benefits of product modelling is one reason why the uptake is slow, but there is a variety of other reasons why the comprehensive use of product modelling is limited to date. These reasons, or rather challenges, were discussed at an international workshop held in January 2003, as part of the 3D to nD modelling project at the University of Salford. According to (Lee 2004), the five biggest challenges for the use of product modelling that were listed by workshop participants are the following (in prioritized order):

- Improving education and changing the industry's culture
- Implementation and integration
- Demonstrating the benefits and value of a product modelling system
- Data issues, such as multiple design perspectives
- Developing a common data standard for interoperability

We will discuss these five challenges in relation to findings and efforts from the IT-stomme project.

9.1 Education and culture

Improving education and changing the industry's culture were seen as the biggest challenges by workshop participants for an uptake of product modelling. Getting industry convinced of benefits and motivating professionals to increase their knowledge about product modelling would greatly facilitate the industry uptake.

It was found that professionals had difficulties in allocating time for education and implementation in addition to their ongoing project work. Due to a lack of education and implemented use cases it was difficult to motivate project actors to consider product modelling as an alternative or improved practice compared to their traditional 2D practice. Most of the modelling work and implementation was therefore performed by a few individuals that limited the learning experience for the total project team.

We suggest the allocation of resources within organizations, rather than in a single project to facilitate the uptake of product modelling. Experience and gained knowledge from product modelling has a bigger chance to sustain within organizations, than in a project team that in many cases ceases to exist after a project has been finished. In addition to strategic uptake of product modelling at a company level, we suggest partnering with other organisations and actors to form a product modelling environment, envisioned by Bazjanac (2004) as a Virtual Building Environment (VBE). A "place" is needed where companies and individuals can get help in creating and using product models across different disciplines.

9.2 Implementation and integration

Implementation and integration was seen as the second biggest challenge by the workshop participants. There are almost no commercial software applications that work with and add to product models beyond 3D modelling (Fischer 2004b).

We illustrated different dimensions of product models by linking different applications and by combining results from these applications. For example, 2D data located at a document server was linked to 3D models. 3D models were used for 4D simulations and 5D cost estimation. In addition to 5D modelling we illustrated a potential n^{th} dimension by integrating property data from a supplier in a product model. These examples illustrated the use of product models beyond 3D modelling.

Although commercially available applications were used for most of the modelling work, there were a number of work arounds and implementations necessary to enable the transition from 3D to nD product model use. Project participants could access the product models by using software, which they already were familiar with. This greatly facilitated the uptake and culture change in the project team towards product modelling.

We suggest starting implementation and integration efforts with existing and commercially available systems as a basis. Sophisticated applications are already available for 3D modelling, production scheduling, cost estimates, et cetera. The challenge is to combine these applications, rather than to develop an all-inclusive modelling system. We illustrated the combination of different commercial applications in the IT-stomme project, instead of developing an own application tailored to our needs. An incremental approach should be adapted in combining different applications with end-user participation in the development process.

9.3 Demonstrating benefits

Demonstrating the benefits and value of a product modelling system was considered the third biggest challenge. Business cases are needed that outlay the needs for product modelling in projects and within organisations.

As noted in the above, motivating participating companies in the IT-stomme project to commit resources for product modelling in future projects was difficult due to difficulties in explicitly communicating benefits from model development and applications in the Hotellviken project. We plan to address this shortcoming by adapting formalized cost benefit analyses developed for the construction industry (Fox 2004). In addition to cost benefit analyses we suggest performance measurement by key performance indicators (Blokpoel 2003), illustrated by a number of product models from different disciplines. One of the tasks of a possible Project Information Officer (PIO) (Froese 2004a) or product model manager could be the collection and analyses of model data to support performance measurement and demonstration of product model benefits.

9.4 Data issues

Data issues were considered a big challenge, but not a high priority to address in research and development of product modelling. Examples of data issues are multiple design perspectives and the information flow, exchange and accuracy in projects.

As a result of different design perspectives it was decided to work with two separate product models; one architectural and one structural model. A hybrid product model view was adapted in addition to these different models in which 3D model data was combined with manually added 2D data. The architectural and structural models were combined in two production models, in which both models were extended and further detailed.

The multi-model approach implied a number of advantages and disadvantages. We believe that separate models per discipline are feasible, but only if adequate tools are used to coordinate these models and to check the consistency of these models. Highly detailed production models are labour intensive to create and to maintain, but are considered valuable instruments to communicate process intend and to evaluate production strategies in a virtual environment, without committing resources on site.

The hybrid document approach proved to be more problematic than the multi-model approach, due to errors in updates of 2D data. With constantly improving commercial 3D modelling tools we believe that a hybrid approach is not a necessity in the future.

9.5 Interoperability

Developing a common data standard for interoperability was perceived by workshop participants as a big challenge, but not a high priority to address. Considerable efforts by the IAI (IAI 2004) to create the IFC product model standard have been made in the last years. Although promising (Kam 2002), the IFCs have not yet found wide acceptance among software vendors and construction companies (Fischer 2004b).

Interoperability was not a major issue in the IT-stomme project as a result of the use of one environment. An architectural model was exported from ArchiCAD and imported to AutoCAD ADT by using IFC2x. The model contained basic objects, such as walls, doors, windows and slabs, and did not result in data losses. The import from ADT to the product model server proved to be more problematic, but was solved in the course of the project. Interoperability is considered essential to start using product models beyond 3D CAD applications. However, the IT-stomme project also showed that different dimensions can be added to a product model independently from standardized data schemas.

10. CONCLUSIONS

The use of product models beyond 3D graphics is currently limited. This paper illustrated a number of dimensions in addition to 3D by combining results from different software applications. Comprehensive use of product models is still limited and uptake is slow, despite advantages of model dimensions illustrated in this paper. Major challenges for the use of product modelling are education, cultural change and the need to demonstrate the value and effectiveness of nD modelling in viable business cases. Research initiatives have mainly concentrated around technical challenges, such as data issues and interoperability. Organizational studies should be prioritised to facilitate the uptake of product modelling in the industry.

Implementations and applications within the IT-stomme project were mainly driven by the interests from a ready mixed concrete supplier who identified product modelling as a threat and as an opportunity for its business process. Modelling cast in place concrete structures implies a number of modelling challenges compared to steel and prefabricated concrete structures, such as the definition of objects. However, the case study project of this study showed that these challenges do not exclude the use of product models for cast in place concrete structures. Advantages and possibilities can be identified for a ready mixed concrete supplier and we believe that other actors in construction can do the same. When actors have identified benefits of product modelling for their own business process they might be more willing to participate in shared product model use in search of benefits for the project team as a whole.

11. ACKNOWLEDGEMENTS

The financial support from SBUF – Development Fund of the Swedish Construction Industry, Betongindustri, Lars Erik Lundbergs Stipendiestiftelse and the European Union's structural funds is acknowledged. The authors

would like to thank HusplanCinnober Arkitekter, JM, Knut Jönsons Ingenjörbyrå and Concode-Intercopy for providing access to project meetings and available information. Enterprixe Software Limited, Ceco, and Sweco-Bloco are acknowledged for the use and support of the Enterprixe modelling system.

12. REFERENCES

- Akbas, R. (2004). "Geometry-based modeling and simulation of construction processes," PhD Thesis, Stanford University, Stanford, CA.
- Autodesk, Inc. (2002). "Building Information Modeling - White Paper." www.autodesk.com/buildinginformation.
- Bazjanac, V. "Virtual building environments (VBE) - applying information modeling to buildings." ECPPM 2004 - eWork and eBusiness in Architecture, Engineering and Construction, Istanbul, Turkey.
- Blokpoel, S. (2003). "Cooperation and Product Modelling Systems - The Application of Product Modelling Systems in the Building Process." Luleå University of Technology, Luleå, Sweden.
- Commonpoint, Inc. (2004). "Commonpoint Project 4D." www.commonpointinc.com.
- DSS. (2004). "Dynamic System Solutions, Line-of-Balance planning systems." www.dss.fi.
- Eastman, C.M. (1992). "Modeling of buildings: evolution and concepts." *Automation in Construction*, 1(2), 99-109.
- Edgar, J-O. (2002). "Prod-IT (98324) 3D Produktmodell som 4D-Produktionsmodell (in Swedish)." *IT Bygg och Fastighet 2002*, Sweden.
- Enterprixe, Ltd. (2002). "Enterprixe White Paper." www.enterprixe.com.
- Fischer, M., Hartmann, T., Rank, E., Neuberg, F., Schreyer, M., Liston, K., and Kunz, J. "Combining different project modelling approaches for effective support of multi-disciplinary engineering tasks." *INCITE 2004 - International Conference on Information Technology in Design and Construction*, Langkawi, Malaysia, 167-182.
- Fox, S. (2004). "The ICT Benefit Formula - First Interim Report." VTT Building and Transport, Espoo, Finland.
- Froese, T.M. "Help wanted: project information officer." *ECPPM 2004 - eWork and eBusiness in Architecture, Engineering and Construction*, Istanbul, Turkey, 19-24.
- Froese, T.M. "Integration of product models with document-based information." *ECPPM 2004 - eWork and eBusiness in Architecture, Engineering and Construction*, Istanbul, Turkey, 85-89.
- Gielingh, W. F. (1989). "General AEC Reference Model (GARM) ISO TC 184/SC4/WG1 Document N329."
- Graphisoft, Inc. (2002). "The Graphisoft Virtual Building: Bringing the Information Model from Concept into Reality - Graphisoft Whitepaper." www.graphisoft.com.
- Hedenblad, G. (1996). "Drying of construction water in concrete - Drying times and moisture measurement." The Moisture Research Group, Lund Institute of Technology, Lund, Sweden.
- Heesom, D., and Mahdjoubi, L. (2004). "Trends of 4D CAD applications for construction planning." *Construction Management and Economics*, February 2004, 22, 171-182, February 2004(22), 171-182.
- IAI. (2004). "International Alliance for Interoperability." <http://www.iai-international.org>.
- Jongeling, R. (2003). "Product modelling for cast in place concrete - a feasibility study." Luleå University of Technology, Luleå, Sweden.
- Jongeling, R., Olofsson, T., and Emborg, M. "Product modelling for industrialized cast-in-place concrete structures." *INCITE 2004 - International Conference on Information Technology in Design and Construction*, Langkawi, Malaysia, 103-110.
- Jongeling, R., Olofsson, T., and Emborg, M. "Modeling cast in place concrete construction alternatives with 4D CAD." *ECPPM 2004 - eWork and eBusiness in Architecture, Engineering and Construction*, Istanbul, Turkey, 109-116.

- Kam, K., Fischer, M. (2002). "Product Model & 4D CAD - Final Report." Center for Integrated Facility Engineering, Stanford University, Stanford, CA.
- Kenley, R. "Project micromanagement: practical site planning and management of work flow." IGLC-12, 12th Conference of the International Group for Lean Construction, Helsingor, Denmark, 194-205.
- Kim, J. (2004, unpubl.). "Generating temporary structures with feature-based 4D models." Department of Civil and Environmental Engineering, Stanford University, Stanford, CA.
- Koo, B., and Fischer, M. (2000). "Feasibility Study of 4D CAD in Commercial Construction." Journal of Construction Engineering and Management, 126(4), 251-260.
- Koo, B., and Fischer, M. (2003). "Formalizing Construction Sequencing Constraints for Rapid Generation of Schedule Alternatives." 75, Center for Integrated Facility Engineering, Stanford University, Stanford, CA.
- Laitinen, J. (1998). "Model based construction process management," PhD thesis, Royal Institute of Technology (KTH), Stockholm, Sweden.
- LCI. (2004). "Lean Construction Institute." www.leanconstruction.org.
- Lee, A., Marshall-Ponting, A.j., Aouad, G., Wu, S., Koh, I., Fu, C., Cooper, R., Betts, M., Kagioglou, M., Fischer, M. (2003). "Developing a Vision of nD-Enabled Construction - Construction IT Report." University of Salford, UK.
- Lee, A., Wu, S., Aouad, G., Fu, C. "nD modelling in construction - buzzword or reality?" INCITE 2004 - International Conference on Information Technology in Design and Construction, Langkawi, Malaysia.
- Mallasi, Z., and Dawood, N. "Registering Space Requirements of Construction Operations Using Site-PECASO Model." CIB w78 conference 2002 - Distributing Knowledge in Building, Aarhus School of Architecture, Denmark, 1-8.
- Navisworks, Ltd. (2004). "Navisworks Clash Detective." www.navisworks.com.
- Solibri, Inc. (2004). "Solibri Model Checker." www.solibri.com.

QUANTITATIVE ANALYSES USING 4D MODELS – AN EXPLORATIVE STUDY

Authors

Rogier Jongeling^a, Jonghoon Kim^b, Claudio Mourgues^b,

Reviewers

Martin Fischer^b, Thomas Olofsson^a

Affiliation

^a eBygg Center, Civil and Environmental Engineering, Luleå University of Technology, Luleå, Sweden

^b Center for Integrated Facility Engineering, Stanford University, USA

Submitted to Automation in Construction, Special Issue on Digital Construction (September 2006)

Abstract

This paper presents time-space analyses of construction operations supported by quantitative information extracted from 4D CAD models. The application of 4D models is a promising approach to help introduce construction innovations and to evaluate construction alternatives. Current analyses of 4D models are mainly visual and provide project stakeholders with a clear, but limited, insight of construction planning information. This practice does not take advantage of the quantitative data contained in 4D models. We use two 4D models of an industry test case to illustrate how to analyze, compare, and present 4D content quantitatively (i.e., work space areas, work locations, and distances between concurrent activities). This paper shows how different types of 4D content can be extracted from 4D models to support 4D-content-based analyses and novel presentation of construction planning information. We suggest further research aimed at formalizing the contents in 4D models to enable comparative quantitative analyses of construction planning alternatives. Formalized 4D content can enable the development of reasoning mechanisms that automate 4D-model-based analyses and provide the data content for presentations of construction planning information.

Keywords

4D CAD, time-space buffer, construction planning, workflow analysis

1. Introduction

The application of 4D CAD models is a promising approach to help introduce construction innovations and to evaluate construction alternatives. 4D modelling is a process method in which schedule data and spatial data are combined. The method visualizes 3D CAD models in a 4-dimensional environment (i.e., time-space environment), facilitating analyses of different production strategies before work on site is initiated (McKinney 1998). 4D models are typically created by linking building components from 3D CAD models with activities from activity-based scheduling methods, such as the Critical Path Method (CPM) (Jongeling 2006). Building components that are related to an ongoing activity are highlighted, providing users with spatial and temporal insights of the construction process. Simulating production options with multiple 4D CAD models from different perspectives allows project stakeholders to compare construction alternatives. However, today these analyses are mainly based on visual analyses where experienced practitioners may or may not detect constructability issues, such as time-space conflicts, that make certain alternatives more or less feasible. Planning supported by visual analyses of 4D CAD models is considered more useful and better than traditional planning (Fischer 2004; Heesom 2004; Koo 2000; Mallasi 2002), but does not take advantage of the quantitative data contained in 4D CAD models.

We present three types of analyses to illustrate the usefulness of quantitative analyses from 4D CAD models for planning of construction operations. The first analysis addresses workflow, workspaces and space buffers. The second analysis concentrates on the planning of temporary structures. The third analysis focuses on crew productivity and production costs. These three analyses are based on temporal and spatial data extracted from 4D models.

1.1. Planning time and space buffers for construction operations

Planning workspace for crews and space between different crews (i.e., space buffers) is a challenging task. Construction planners need to carefully design time-space buffers between activities so that on one hand the productivity for each crew is not slowed by time-space conflicts and lack of workspace and on the other hand the overall schedule is not lengthened due to excessive use of time-space buffers. This planning task is extra challenging because the space usage on construction sites changes dynamically. Different crews move across the site from one work location to another. To execute their work, construction crews use, among other things, temporary structures. Temporary structures are

one of the important factors in planning workspace and time-space buffers as they occupy space, but also provide work space depending on the stage of a construction project. The output of crews (i.e., the productivity of crews) is strongly dependent on available workspace and affects the progress on projects, and ultimately the project cost. Traditional scheduling techniques, such as the Critical Path Method (CPM), used in combination with 2D drawings, provide planners with limited spatial insight that is required for the planning of efficient workspace use and allocation of optimal time-space buffers. In the traditional approach using CPM and 2D drawings users are required to look at 2D drawings to conceptually associate building components with the related activities (Koo 2000). Different actors may develop inconsistent interpretations of the relations between activities in a schedule and project components. This practice is prone to errors and limits the understanding of the spatial context of the flow of construction work on projects.

Virtual environments, such as virtual reality (VR) and 4D CAD, promote improved understanding of construction operations (Li 2003). Akinci et al. (Akinci 2002) formalize and model space usage for construction activities in 4D CAD models, resulting in space-loaded 4D CAD models. The formalization and modeling methods provide insight into various types of spaces that are related to specific types of construction activities and potential conflicts (e.g., material space, labor space, building component space, etc.), but do not provide insight into the efficiency of designed time-space buffers between different activities. The Line-of-Balance (LoB) method (Kenley 2004) provides spatial insight into the planning of time-space buffers and workspaces in the construction process. This technique uses lines to represent the production of crews over time in diagrams. LoB diagrams are based on a well-defined spatial sub-system, such as a floor consisting of apartments, divided into rooms. This type of static spatial hierarchy of workspaces is not present during all stages of the construction process. The distribution of and boundaries between workspaces are generally much more complex and less clear. Projects can have complex workflow directions of crews as a result of variations in the spatial configuration of a project. Akbas (Akbas 2004) proposes a geometry-based process model (GPM) that uses geometric models to model and simulate workflows and work locations. This method provides spatial insight into the planning of workspaces and space buffers for repetitive crew activities, but has not been applied for quantitative analyses of 4D CAD models. It has rather been used as a simulation method for workflow and work locations with detailed 4D CAD models as an output.

1.2. Quantitative analyses using 4D models

In this paper we show the value and method of extracting data from 4D CAD models to enable quantitative analyses of 4D CAD models. The basis for analysis is the 4D CAD model and not the underlying scheduling and modeling method for these models, such as the CPM schedule, LoB diagram, or GPM simulation.

This paper first introduces 4D CAD models of an industry test case that we use as a case example. Then, the paper describes quantitative analyses of the 4D CAD models, in which we analyze workflow and planning of temporary structures. In addition, we perform an analysis in which we relate crew productivity and production costs to extracted data from the 4D CAD models. The paper concludes by suggesting research directions for development of 4D CAD systems that support quantitative analyses of 4D CAD models.

2. Industry Case Example

In an effort to adequately support the introduction and evaluation of innovations in the construction process (i.e., prefabricated reinforcement, permanent formwork, self-compacting concrete, etc.) Betongindustri AB, a Swedish ready mix concrete supplier (Jongeling 2004) initiated a pilot study using 4D CAD simulations to evaluate two construction alternatives of a residential construction project. The concrete supplier conducted the experiments after the actual construction of the project was finished. The experiments are realistic and, where possible, are based on actual site data, but had no direct impact on the construction process performed by the contractor. The 4D CAD simulations by the concrete supplier include construction operations related to concrete walls and slabs, but the analyses of these models performed in this study are limited to analyses of simulated construction operations related to the casting process of concrete slabs.

The first alternative, the traditional scenario, represents today's common practice for cast-in-place concrete construction. The objective of this scenario is to represent a typical set of construction activities that are related to casting of concrete. The second alternative provides an industrialized approach to cast-in-place concrete construction utilizing permanent formwork systems in combination with the use of prefabricated carpets of reinforcement and self-compacting concrete. The objective of the pilot study by the concrete supplier

was to visualize the potential for such an industrialized construction method. Such a combination of innovative production technologies has not been applied on actual projects in Sweden.

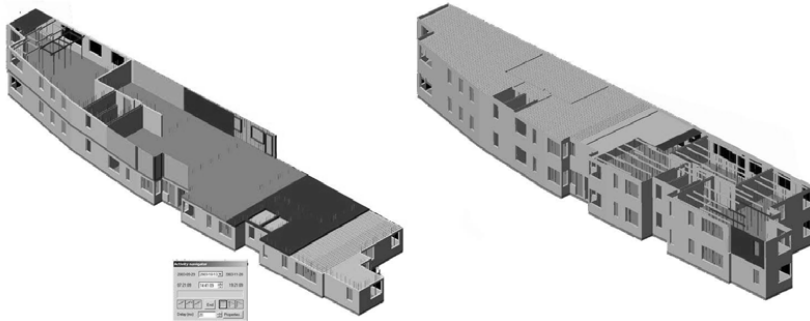

Figure 1: Snapshots of the 4D models of two construction alternatives.

The concrete supplier used the 4D simulations in seminars in which a variety of construction professionals were invited. The 4D models provided the professionals from different disciplines an integrated visual impression of the two construction alternatives, but were limited in the sense that it was not possible to extract quantitative data from the 4D CAD models to articulate the differences and benefits of the new method more fully and clearly. In addition to the graphical output of 4D CAD models, there was a need to quantify the results from the simulations to allow comparison of construction alternatives on different aspects, such as workspace planning, temporary structure planning, and crew productivity. These findings formed the basis and motivation for our study where we used the 4D CAD models created by the concrete supplier to extract data that we used for different analyses. Before we discuss these analyses, we first introduce the 4D CAD models of the case study.

2.1. 4D CAD Models of the Case Study

The concrete supplier used an architectural 3D CAD model as the base model for the 4D CAD simulations. The 3D CAD objects of this model were not detailed enough to be used for representation of specific construction operations. The concrete supplier therefore transformed the architectural model into a model suitable for simulation of construction operations by adding detail to the 3D model. The concrete slab, for example, is modeled as one object in

the architectural model, but is poured in several sections. The supplier, therefore, split the slab into separate casting objects.

The complete 3D model consists of four 3D CAD models that are based on the architectural model and represent four successive construction trades:

- Shoring to support formwork elements
- Formwork elements on which reinforcement is installed and concrete is poured
- Reinforcement bars
- Pouring of concrete sections

In addition to the 3D CAD models, the concrete supplier created detailed schedules for both alternatives, resulting in CPM schedules with 111 activities for a single slab of 60 meters in length and 15 meters in width. We linked these activities with the components in the 3D model to make the 4D models. Planners at the concrete supplier detailed and grouped all activities in the CPM schedules in four two-hour work packages per day.

2.2. Casting Sections

The concrete supplier defined casting sequences for concrete work by splitting the 3D CAD model into a number of sections. The supplier planned two scenarios per construction alternative. Table 1 and Figure 2 show a scenario in which the slab is cast in two sections and another scenario in which the slab is cast in three sections. Table 1 includes all the simulated construction alternatives.

Alternatives	Two sections	Three sections
Traditional	Traditional II	Traditional III
Industrialized	Industrialized II	Industrialized III

Table 1: Simulated construction alternatives in 4D CAD

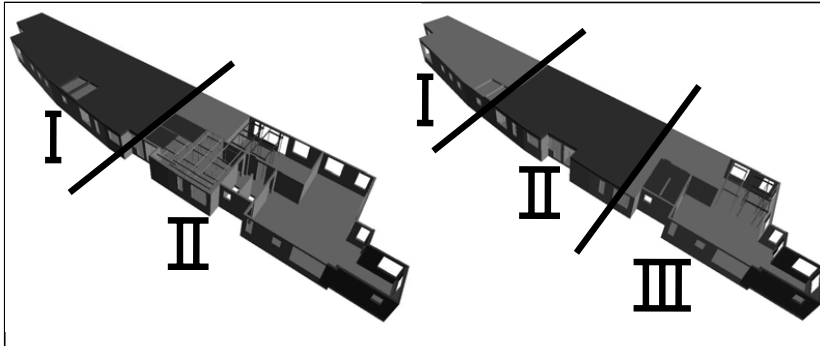

Figure 2: Snapshots of a 4D CAD simulation of two traditional construction alternatives for the construction of a residential structure. Dark grey elements are ongoing at the time of the snapshot. Left: casting the concrete slab in two sections (Traditional II). Right: casting the concrete slab in three sections (Traditional III).

The supplier determined the length and distribution of the sections for concrete work by considering the following aspects: overall project duration, required formwork, volume of concrete, workflow direction, and possible workspace conflicts. These aspects were considered implicitly and were not quantified in the decision-making process. The supplier planned the required temporary structures after having determined the length and distribution of the sections for concrete work.

2.3. Temporary Structures

Temporary structure plans are different for the traditional and industrialized construction alternatives. The traditional alternative is based on the use of traditional temporary formwork elements, supported by shoring, whereas the industrialized alternative is based on a permanent formwork system. This formwork consists of cement-bonded particle boards, which remain in the building after construction.

The concrete supplier considered two types of temporary structures for casting of the slab in the modeling work, Figure 3:

- Shoring to support formwork elements for the slab.
- Formwork elements on which reinforcement is installed and concrete is poured.

The supplier grouped the formwork and shoring in the 3D CAD model in work packages, based on their location and size, and an assumed productivity of the planned crew for erection of the temporary structures. This resulted in 31 formwork and shoring work packages, each representing two hours of erection work.

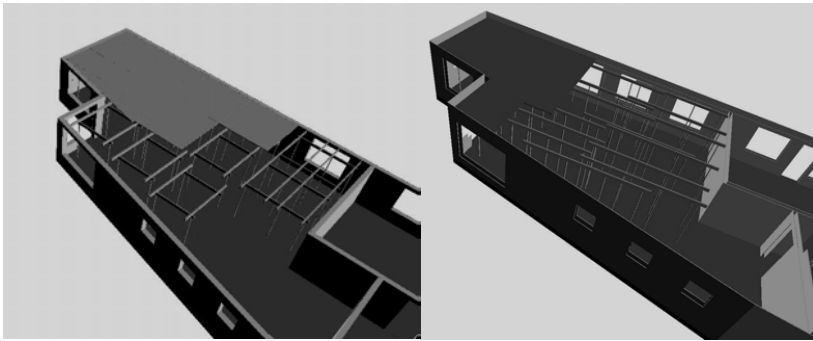

Figure 3: Temporary structures for the concrete slab shown in 4D CAD models. Left: in the traditional construction alternative temporary formwork is supported by shoring. Right: permanent formwork was used for the industrialized alternative, which is supported by shoring.

2.4. Reinforcement

The purpose of the reinforcement bars was to show the reinforcement activity workspaces in the 4D CAD models rather than the actual reinforcement components, Figure 4. The concrete supplier determined the dimensions, locations and number of reinforcement bars in the 3D CAD model for this specific visual purpose and did not model all reinforcement bars in exact detail. The supplier distributed the reinforcement bars over equal distances and modeled the bars in one direction in order to minimize the 3D modeling work. The supplier then grouped the reinforcement bars into two-hour work packages, based on assumed productivity of the crew for placement of the reinforcement bars on site, resulting into 30 two-hour work packages. The concrete supplier planned the placement of reinforcement bars with the assumption of a constant production rate (i.e., every reinforcement bar would take the same amount of time) and did not take specific geometrical situations

such as elevator shafts into account to calculate location-specific production rates (as, e.g., done by Akbas [10]).

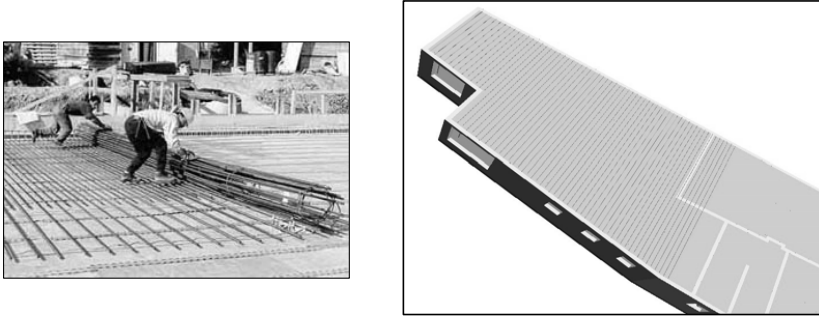

Figure 4: Left: the industrialized alternative contains prefabricated reinforcement carpets, as opposed to the traditional alternative, which contains traditional reinforcement bars. Right: approximate representation of reinforcement bars in a 3D CAD model.

The supplier used the 4D models in seminars to show the industrialized and traditional construction alternatives in parallel. Participants at the seminars considered this parallel visualization a very effective way to visually explain the differences between the industrialized and traditional construction methods. However, the participants also asked for quantitative data that could support their interpretation of the 4D models. Participants from different disciplines were interested in making specific data analyses of the 4D models. In addition to the visual comparison in 4D, these actors were interested in making data analyses of, for example, distances between parallel work flows, amount of used formwork, available work spaces, etc. The supplier could not extract the data that was needed to make these analyses from the available 4D models. These data would have been useful to understand when and where the construction schedule could be improved.

In summary, the 4D models built by the concrete supplier were useful to visually compare construction alternatives, but limited in the sense that quantitative data could not be extracted. The supplier identified a need to quantify the results from the visual analyses to allow for comparison of construction alternatives. The observations from this 4D modeling study by the concrete supplier are a basis for analyses from 4D CAD models.

3. Analyses of 4D CAD models

We conducted three types of analyses to study and illustrate the potential of 4D CAD beyond visual analyses. The first analysis originated from recognizing the spatial nature of construction work and the way in which the work moves over a construction site during construction. The second analysis concentrated on the planning of temporary structures, in which we applied the same spatial data from the 4D CAD models as used in the first analysis. The third analysis combines crew productivity and production costs with extracted 4D content. We define 4D content as information present in a 4D CAD model, such as distances between concurrent activities.

As a basis for our analyses, we manually inspected the 4D models and collected the required data in spreadsheets for every two hours of construction time simulated in the 4D CAD models and added cost and resource data. We performed the data collection and data analyses manually to understand the data thoroughly, but this process could be automated with appropriate mechanisms. We joined the spatial analysis and the resource use and cost analysis in a combined analysis to explore the relation of spatial data and productivity of crews.

3.1. Spatial Analyses

We extracted the following data from the 4D models:

- Workspace areas used per construction trade
- Distances between concurrent activities of different trades

Examples of the spreadsheets from the traditional construction alternative that is cast in three sections are included in Tables 2 and 3. The tables show data from the 4D model simulation of the construction process on days 3, 4, and 5. Table 2 shows used and available workspace. The used workspace is measured by the size of the CAD components associated with ongoing construction activities. The available workspace is derived from the sequence of trades and their output according to the following logic: the trade that installs shoring creates workspace for formwork. Formwork in turn provides workspace for the reinforcement trade, and so on. Table 3 shows two types of distances that we extracted from the 4D model. The distances between the activities' centers are measured from the center of the work space of one activity to another activity's center. The closest distance is measured at the point where the distance between the work spaces of two concurrent activities is minimal.

Duration	Used work space area (m2)					Available work space area (m2)				
	Shoring	Form	Rebar	Concrete	Total	Shoring	Form	Rebar	Concrete	Total
Day 3										
08 - 10	20	14	15	0	49	n/a	32	103	70	205
10 - 12	16	15	16	0	47	n/a	38	102	92	232
13 - 15	14	18	22	0	54	n/a	39	101	116	256
15 - 17	14	17	17	0	48	n/a	35	97	0	132
Day 4										
08 - 10	14	18	22	0	54	n/a	32	97	0	129
10 - 12	15	0	24	0	39	n/a	28	93	116	237
13 - 15	16	14	18	0	48	n/a	43	69	116	228
15 - 17	22	17	12	0	51	n/a	45	65	134	244
Day 5										
08 - 10	17	12	16	0	45	n/a	50	70	146	266
10 - 12	17	18	0	80	115	n/a	55	66	162	283
13 - 15	17	22	24	80	143	n/a	54	84	82	220
15 - 17	17	18	30	0	65	n/a	49	82	26	157

Table 2: Example of used and available workspace data extracted from 4D models and collected in spreadsheets. The table shows data from the traditional III construction alternative which is cast in three sections on days 3, 4 and 5.

Duration	Distances between centers (m)				Distances between boundaries (m)			
	Shoring	Shoring	Form	Rebar	Shoring	Shoring	Form	Rebar
	to	to	to	to	to	to	to	to
	Form	Rebar	Rebar	Concrete	Form	Rebar	Rebar	Concrete
Day 3								
08 - 10	7	18	8	-	4	15	2	-
10 - 12	6	14	10	-	1	11	8	-
13 - 15	7	18	9	-	2	15	7	-
15 - 17	4	15	8	-	0.5	13	6	-
Day 4								
08 - 10	6	12	6	-	3	9	4	-
10 - 12	3	9	-	-	0.5	6	-	-
13 - 15	4	11	6	-	0.5	8	4	-
15 - 17	5	12	6	-	2	9	4	-
Day 5								
08 - 10	8	14	4	-	5	10	2	-
10 - 12	6	-	-	-	0.5	-	-	-
13 - 15	6	11	4	15	0.5	7	1	0.5
15 - 17	6	7	5	-	4	3	2	-

Table 3: Example of distances between concurrent activities extracted from 4D models and collected in spreadsheets. The table shows data from the traditional III construction alternative which is cast in three sections on days 3, 4 and 5, which is cast in three sections.

3.1.1. Used Workspace

Figure 5 presents the used workspace in square meters (Y-axis) per trade in two hour intervals per construction day (X-axis) for the traditional and industrialized construction alternatives that are cast in three sections (traditional III and industrialized III). The upper graph in Figure 5 shows the work on three sections of the traditional III alternative during 10 construction days in which the workspaces used by shoring and formwork activities are fairly constant and measure approximately 20m^2 .

The total construction time of the industrialized alternative is shorter than the traditional alternative, resulting in higher average total space usage for the industrialized alternative. The lower graph in Figure 5 shows that the industrialized III construction alternative has a much more widely varying workspace use as opposed to the fairly constant workspace use shown in the upper graph in Figure 5. Workspace used by shoring activities during the first two days is around 40 to 60m^2 after which it drops to 0m^2 on day 3. Formwork and reinforcement activities have similar space use patterns. This 4D CAD model does not show production problems on day 3 of construction for the Industrialized III alternative, such as workspace conflicts. However, the concrete supplier experienced difficulties in planning space buffers between the successive trades and needed a number of iterations to create a 4D CAD model without time-space conflicts.

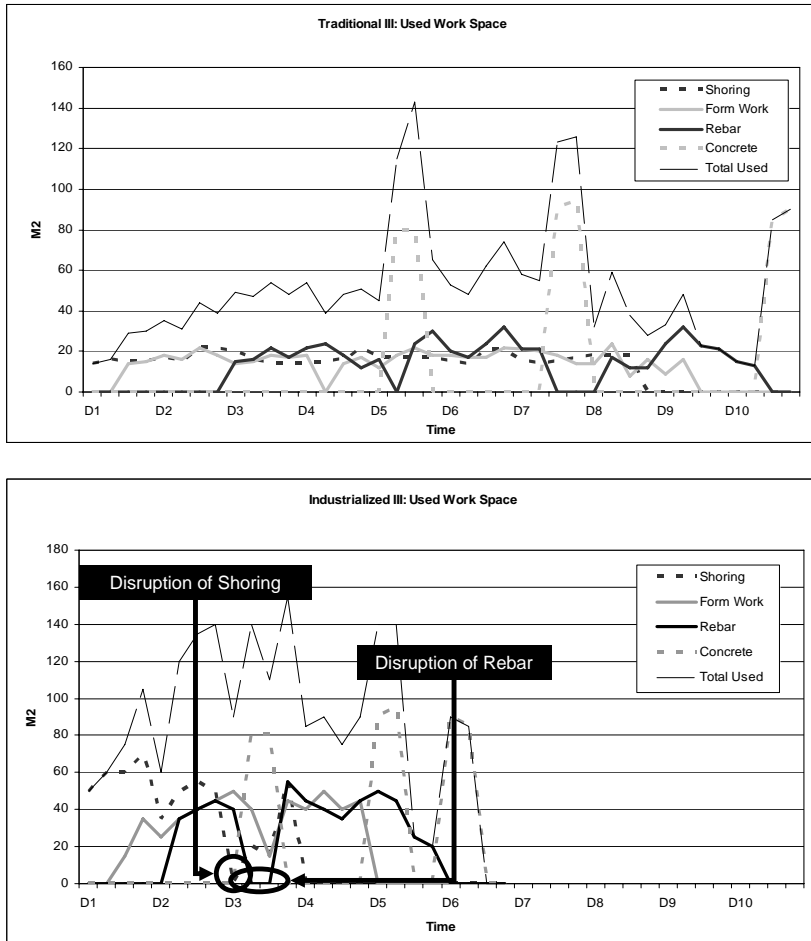

Figure 5: The upper graph shows the used workspace extracted from the 4D CAD model of the traditional III alternative. The lower graph shows the used workspace of the Industrialized III alternative.

The following planning decisions and planning rationale led to such disruptions in the workflow:

- Planners at the concrete supplier assumed that the laborers needed for casting concrete on day 3 could be used from the shoring activities. As a result, shoring activities were halted during the first 2 hours on day 3.
- The initial time-space buffer between the successive trades was too small. A short stop in the shoring activities resulted in a lack of available workspace for formwork, which in turn limited the reinforcement installation activities.
- The focus was on planning each trade individually instead of planning the overall project. The activity start was prioritized in the planning process, with too little consideration for the total activity duration and time-space status of these activities. The 4D CAD model was used to filter out severe time-space conflicts between different activities, but was not used to optimize the workflow.

In summary, the planning of the industrialized construction alternative was sub-optimized by trade, because the planners focused on one trade at the time. The planners did not make explicit consideration of the time-space status of activities resulting in disruption in workflow. These disruptions did not become directly clear from the CPM schedule or from the 4D CAD model, but became obvious from representation of the used workspaces of different trades in time, as shown in Figure 5.

3.1.2. Distances between trades

In addition to workspace used, we analyzed distances between concurrent activities of different construction trades. These distances indicate the amount of space buffers that are allocated by planners between different activities. These data can possibly be useful for planners in allocating sufficient workspace for construction crews. Allocating too much space distances activities too much and lengthens project duration. Allocating too little space reduces productivity, which also lengthens project duration.

Figure 6 shows the distances between the formwork and reinforcement activities for the traditional alternative. As mentioned, we measured two types of distances for every construction day per two hour interval (X-axis): distances between the activities' centers and the closest distances between two trades (Y-axis).

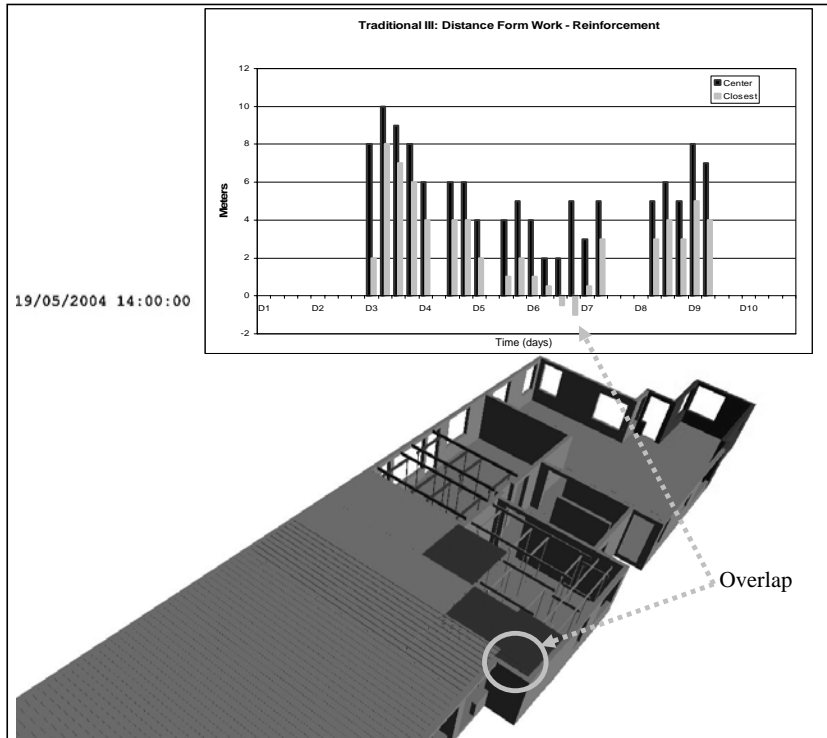

Figure 6: The upper graph shows the distances between formwork and reinforcement trades for the traditional III case. The lower figure, a snapshot from the 4D simulation, depicts the situation when the distances graphed above become negative.

The formwork and reinforcement activities are close to each other during days 3, 4, 5 and 6. On day 6 the activities overlap, as shown by the negative distance between the two construction trades. This overlap, or time-space conflict, was overlooked in the 4D CAD model, but became immediately obvious in the graph showing the distances between trades.

The analyses of used workspace and distances between trades illustrate that not all spatial data of 4D CAD models become explicit in the typical form of 4D snapshots or 4D movies. These analyses show that additional representations and presentations of 4D CAD model information, such as graphs, are needed to

efficiently allocate work space and space buffers between concurrent activities for productive work by construction crews.

3.2. Temporary Structures

The motivation for this analysis comes from difficulties in planning and evaluating alternative plans for temporary structures. Without evaluation of alternatives, temporary structure planning decisions may be less feasible and have negative impacts on the overall construction process (e.g., schedule delay due to unexpected time-space conflicts). Temporary structures, such as shoring and scaffolding, limit the available work space and in many cases cause time-space conflicts for some activities, but also create work space for other activities. In this section, we discuss how temporary structure plans (i.e., shoring plans) relate to space use during construction. First, we describe how the duration of shoring use in the traditional and industrialized alternatives differs and thereby affects the space used by the temporary structures. Secondly, we analyze the distances between shoring and formwork activities to illustrate how different shoring plans affect the flow of work by different trades.

3.2.1. Space used by temporary structures

To analyze how long and how much space the shoring in the construction alternatives of the case study needs, we measured the amount of space taken by shoring and the duration that is associated with the space. The duration to keep shoring was obtained by calculating the time between the installation and dismantlement of the shoring. The construction processes for the concrete slab in the traditional and industrialized alternatives are different, resulting in different shoring plans. To compare the durations of shoring use for the same location and for the same amount of space, we split the shoring that covered the whole slab into thirty-one different blocks (Figure 7), according to the total number of shoring activities in the traditional approach.

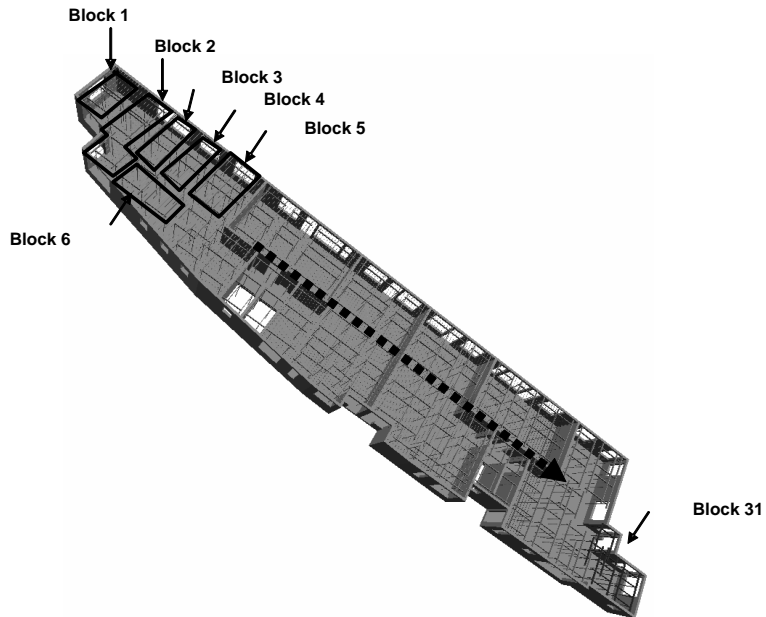

Figure 7: Blocks of shoring. We split the shoring that covered the whole slab into thirty-one different blocks, according to the total number of shoring activities in the traditional approach.

The graph in Figure 8 shows the durations of shoring use for the traditional and industrialized alternatives. Overall, the traditional alternative needs to keep the shoring for the slab longer than the industrialized alternative. Other than the overall shoring use time, the graph also shows that the difference in the duration of shoring use is bigger for the early blocks of the slab than for the later blocks.

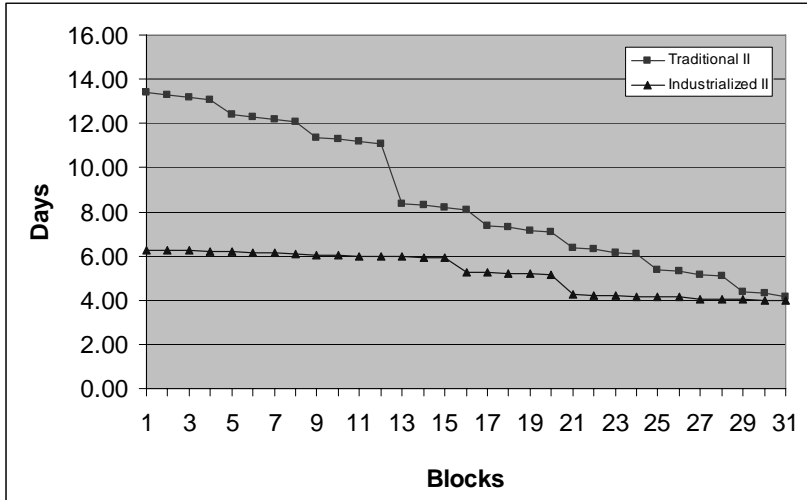

Figure 8: Durations from erection to dismantlement of the shoring in each block.

The permanent formwork system used for the industrialized construction alternative enabled the formwork and reinforcement trades to proceed faster than in the traditional alternative, resulting in earlier casting of concrete and removal of the shoring. The longer duration to keep shoring in the traditional alternative has more potential to cause time-space conflicts (Akinci 2002) than the industrialized approach. In addition to the higher potential time-space conflicts, the traditional alternative is less efficient than the industrialized alternative in terms of reuse of shoring material in other parts of the project because the longer duration to keep the shoring in one place in the traditional alternative means there is less opportunity to use the shoring in other places of the project.

This analysis illustrates that measuring the space taken by temporary structures and the time of temporary structure use in a quantitative way supports comparing and evaluating alternatives of temporary structure plans in terms of potential of time-space conflicts and efficiency of resource reuse (i.e., material for temporary structures). It also shows that using similar break-ups (i.e., same

number and size of blocks) of temporary structures facilitates comparative analyses of different shoring plans.

3.2.2. Distances between shoring and formwork

To understand how different shoring plans in the traditional and industrialized approaches affect the workflow of activities following each other (i.e., formwork), we analyzed the distances between shoring and formwork activities in a similar way as presented in section 3.1.2. As shown in Figures 9 and 10, the activities of shoring and formwork in the traditional alternative are closer to each other than the activities in the industrialized alternative. The industrialized alternative requires a simple type of shoring with short durations for installation and dismantlement. Hence, the shoring in the industrialized approach proceeds fast, resulting in an increased distance from the formwork. The large distance between two sequential activities (i.e., shoring and formwork) in the industrialized alternative decreases the potential of space conflicts between the two construction trades. However, the distances between the two sequential activities in the industrialized alternative might be unnecessarily long. The increased distance represents more work in progress that is potentially needed and might have negative impact on the workflow of other activities (Koo 2000). For example, the shoring installed far from ongoing slab formwork activities may block movements of workers or materials, thereby reducing productivity of the activity that requires the space.

In addition, we performed two analyses within one construction alternative to see how the workflow direction of one trade affects overall workflow. In this analysis, we defined two different directions of workflows of shoring activities and measured distances between trades for shoring and formwork. Figure 11 shows the definition of the direction of shoring. In Figure 11 (left), the workflow of the shoring activities is the same as the workflow for the formwork activities. The shoring in Figure 11 (right) starts from the point where it ends in the previous blocks. Hence, the workflow of shoring can be different in some blocks where the workflow direction of shoring differs from that of formwork. To measure the distances between shoring and formwork, we manually calculated the distance between the starting points of formwork and shoring. The result of the analysis is shown in Figure 12. Although the workflow patterns of the two alternatives are similar, the graph shows differences between the two alternatives on certain days (e.g., day 3, 4, 5, 8). This analysis also shows that the fluctuation of the distance between formwork and shoring is affected by the workflow directions of the individual trades. The fluctuation of the distance between formwork and shoring is smaller (standard

deviation: 3.83) when the directions of the workflows are the same (Figure 11 left) compared to the alternative with different workflow directions (Figure 11 right, standard deviation: 4.44).

The analyses illustrate that the distances between activities for temporary structures and other related activities need to be considered to plan temporary structures and compare alternatives of temporary structure plans. The speed and workflow direction of temporary structure activities and related activities determine the distances and pattern of the distances (Akbas 2004). As a result, when we measure and illustrate the distances between the activities in different alternatives of temporary structure plans, we can analyze and evaluate how appropriately the workflow (i.e., speed and direction) of the activities of temporary structures is planned. As indicated in 3.1.2, 4D snapshots and 4D movies from current 4D tools do not explicitly represent the distance between temporary structures and other related activities.

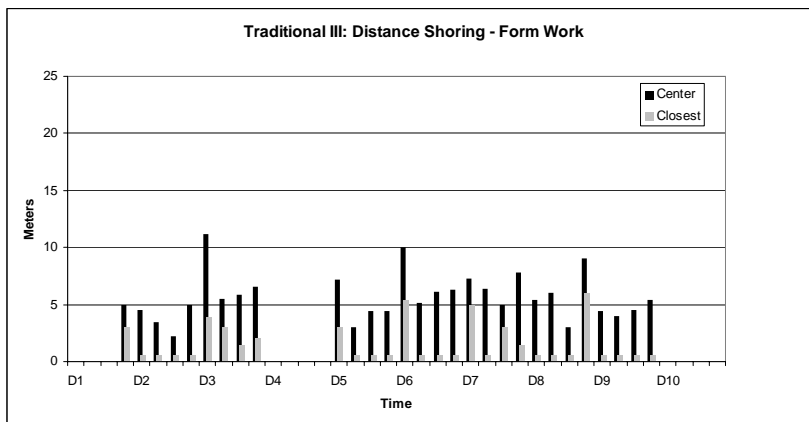

Figure 9: Traditional III: Distances between shoring and formwork activities.

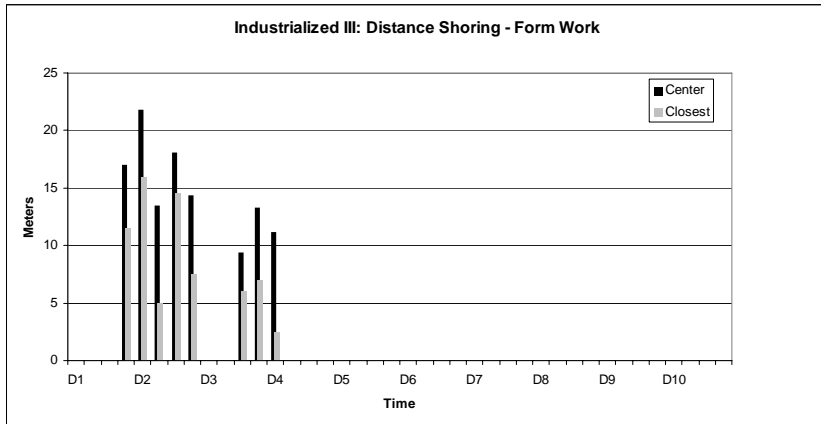

Figure 10: Industrialized III: Distances between shoring and formwork activities.

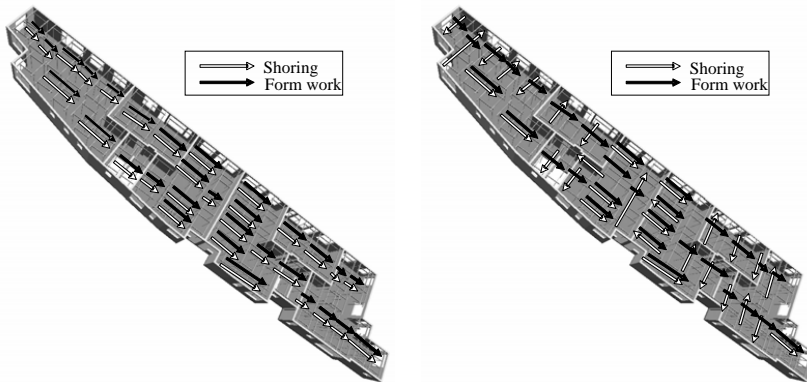

Figure 11: Direction of workflows of shoring and formwork activities. Left: the workflow of the shoring activities was the same as the workflow for the formwork activities. Right: the shoring starts from the point where it ends in the previous blocks.

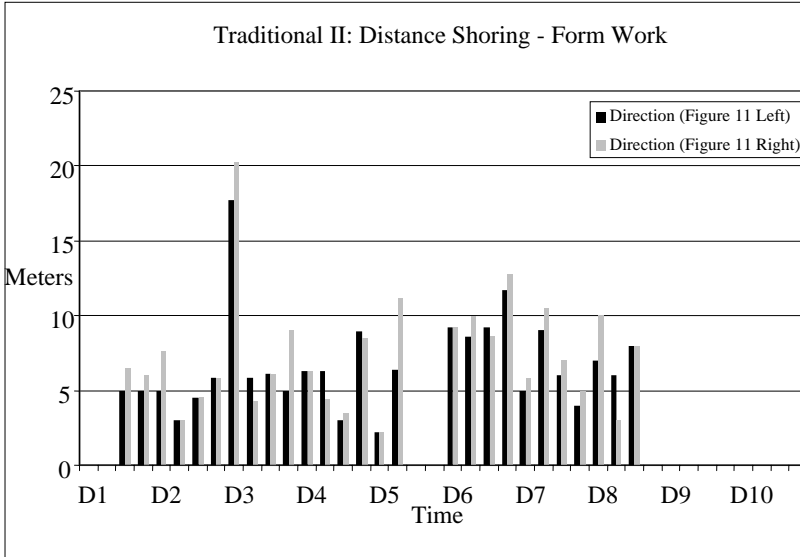

Figure 12: Distances between shoring and formwork activities.

The analyses of temporary structures presented in this article show that quantitative analyses of 4D content (i.e., amount of space, time, distance, speed, direction) help construction engineers evaluate how the use of temporary structures affects the overall workflow and resource use. Previous approaches formalized ways to represent and manage the 4D content in 4D CAD environment (Akinici 2002). However, the approaches and current 4D CAD modeling tools do not provide functionalities to perform the analyses of temporary structures in a quantitative way. Hence, it is difficult for construction engineers to evaluate temporary structure plans thoroughly to make them more feasible for the given situation or to compare different construction alternatives.

3.3. Impacts on productivity and production costs

We also studied how extracted 4D content relates to crew productivity and production cost. Estimates for crew productivity and production costs for each trade and for all construction alternatives are based on data obtained from industry professionals, such as planners, cost estimators, and suppliers of concrete, formwork, and reinforcement. The productivity estimates that we

used assumed a constant productivity rate for each trade during the project. However, productivities are usually not constant, and available workspace is one of the factors affecting productivity. Figure 6 shows a specific moment of the 4D simulation when the closest distance between formwork and reinforcement becomes negative, implying an overlap of trades.

To estimate the impact of the detected conflict between trades, we established a relation between trade distances (a specific 4D content) and trade productivities, summarized in Table 4. We established this relation for illustrative purposes by assuming impacts on productivity based on the distance between trades. We considered the trades separately: a predecessor and a successor. In this case example the reinforcement trade is a successor to the formwork trade and is dependent on the outcome of the formwork activities.

Distance between trades	Assumed productivity of successor trade	Assumed productivity of predecessor trade
> 2m	100%	100%
1-2m	50%	75%
0-1m	25%	50%
< 0m	(cannot work) 0%	100%

Table 4: Assumed relation between the productivities of construction trades and the distance between formwork and reinforcement trades.

Like in other prototype 4D modeling systems [6], we adjusted the productivities that were given by planners and technology providers for the specific trade conflict as noted in Figure 6. Table 5 shows the adjusted productivity percentages with an interval of two hours for the reinforcement and formwork trades on day 6, the day on which the trade conflict occurs. The bottom row shows the average productivity of the day.

Day 6 Time	% assumed productivity	Closest distance between trades (m)	Productivity of formwork	Productivity of reinforcement
08h-10h	100%	1.0	75%	50%
10h-12h	100%	0.5	50%	25%
13h-15h	100%	(conflict) -0.5	100%	0%
15h-17h	100%	(conflict) -1.0	100%	0%
Average	100%		81%	19%

Table 5: Modifications of assumed productivities based on trade distances.

The conflict between the two trades results in lower average productivity (lower daily production) on day 6 for both trades (resp. 81% and 19%) than the assumed productivity (100%). Extra work is needed for formwork and reinforcement installation on days 7 and 8 to compensate for the lower productivity on day 6. Extra work results in higher resource use and consequently higher costs, compared to the original planning and cost estimation (O'Brien 1975). Figure 13 shows the difference in labor costs due to the conflict between trades on construction day 6 for the traditional III construction alternative. Labor costs are calculated by multiplying the costs per laborer with the required duration of work.

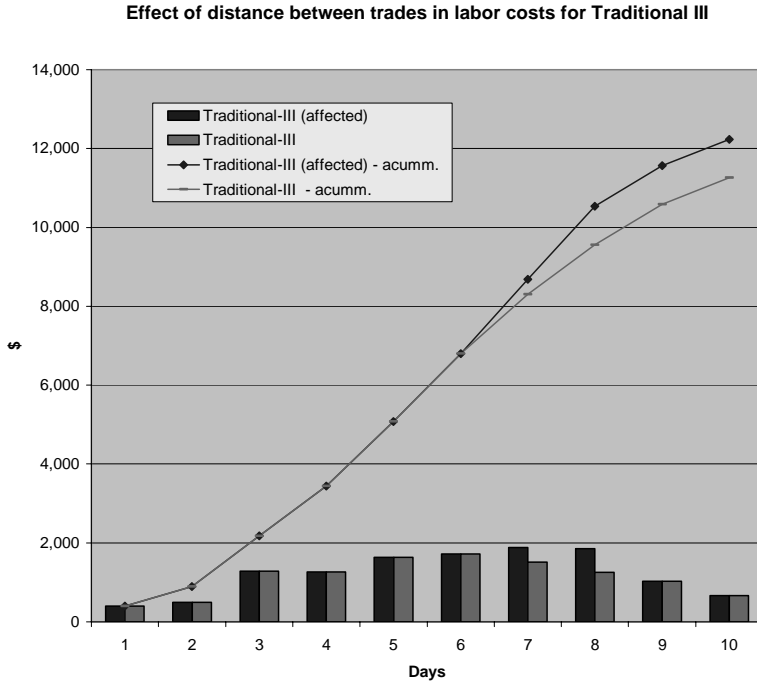

Figure 13: Effect of variation of distances between formwork and reinforcement trades on labor costs.

The extra cost corresponds to the labor cost of the extra time needed to finish the work that could not be performed on day 6 due to the lower productivity. With our assumptions the extra cost is approximately 7% of the total production cost (shoring, formwork, reinforcement, and concrete) of the slab construction. This insight into the impact on crew productivity and production cost could not be obtained from visual analyses of the 4D CAD model.

4. Discussion and Further Research

Although based on a real case and realistic production data, the specific numeric results of the presented analyses are hypothetical, but show a type of

reasoning or analysis that does not occur in today's 4D CAD simulations. Reasoning, such as analyzing distances between trades and re-routing formwork trades, is done on the construction site where there is a limited opportunity to change construction execution strategies. The distance between different types of work is an important factor in safe and productive execution of work. This paper showed that early analyses of 4D content can limit the risk for time-space conflicts in production. In addition to minimizing risks, there is also a potential to use analyses of 4D content to improve construction processes on aspects such as workspace usage and resource usage. The analyses of 4D content that were performed in this study showed, for example, disruptions in workspace usage that did not become clear from CPM schedules or from 4D CAD models. Representation of workspaces of different trades in a graph made these disruptions explicit and illustrated the usefulness of extracting data from 4D CAD models.

In the process of manually extracting the 4D content we made certain assumptions about how to measure, for example, distances between trades. We measured distances in the horizontal (XY) plane and did not consider differences in height. In addition, we assumed that the 3D CAD components represented the workspace used by crews, but in reality the workspace used by crews is not limited to these components (Riley 1995). Representation and interpretation of extracted 4D content calls for an accompanying 4D CAD model to understand the meaning of these data and to put the data in a spatial and temporal context that the 4D CAD model provides.

4D CAD models come in different levels of detail and with different contents. Certain 4D CAD models are, for example, workspace loaded [2], and other 4D CAD models contain a temporary structure plan. How to extract 4D content from a 4D CAD model therefore depends on the type of 4D CAD model that is available. As a result, the process of querying 4D content is currently not a straightforward database query in time, since there is no agreed upon standard for defining and managing 4D content of 4D CAD models. To illustrate this, 4D CAD objects that represent shoring in the 4D CAD models of the industry case study have the same object property definitions as objects that represent formwork. The lack of specific definitions for these objects and the lack of instruction for the use of these definitions for modelers require custom-built reasoning mechanisms to extract 4D content such as distances between trades automatically from a 4D model.

Certain 4D CAD software tools (Heesom 2004) offer functionality to specify the type of activity in 4D CAD models (i.e., activity types), which works in a

similar way as CAD layers in 3D CAD tools. Using activity types can be one way of defining specific 4D contents, which in turn could enable the automatic extraction of these contents. However, activity types are not always used in 4D CAD models, nor are they available in all 4D CAD software tools [4]. In the 4D CAD software tools that support activity types there is currently no functionality available to query the 4D CAD model for specific types of activities. The technical challenges of developing such functionality are minimal. However, the process to input 4D content and to extract this content requires further research.

In this paper we illustrated a number of 4D contents, with different analyses, but there are most probably more 4D contents that can be of interest for the design, planning, and control of the construction process. We suggest further research where different types of 4D content are extracted and analyzed from 4D CAD models. Combined, these studies can eventually result in sets of 4D contents, reasoning mechanisms, and information presentations that are standardized for different types of analyses. The standard 4D contents and subsequent analyses can be expressed as a set of metrics that can provide planners with a basis to compare construction planning alternatives for different aspects.

Acknowledgements

This paper is based on a case study project by Betongindustri AB in Sweden. We thank Thorbjörn Dorbell, Mats Emborg, and Anders Ingnäs for their commitment and patience in supporting our work. The 4D models of the case study were modeled by using software from Commonpoint Inc. and Enterprixe Ltd. We thank both companies for their support and for providing us access to their software. The financial support from the Swedish research fund for environment, agricultural sciences and spatial planning (Formas), the Lars Erik Lundbergs Stipendiestiftelse, the Swedish construction development fund (SBUF) and the European regional funds is acknowledged. We also gratefully acknowledge the support of the Center for Integrated Facility Engineering and its members at Stanford University.

References

- Akbas, R. (2004). "Geometry-based modeling and simulation of construction processes," PhD Thesis, Stanford University, Stanford, CA.
- Akinci, B., Fischer, M., and Kunz, J. (2002). "Automated Generation of Work Spaces Required by Construction Activities." *Journal of Construction Engineering and Management*, 128(4), 10.
- Fischer, M., Hartmann, T., Rank, E., Neuberg, F., Schreyer, M., Liston, K., and Kunz, J. (2004) "Combining different project modelling approaches for effective support of multi-disciplinary engineering tasks." In P. Brandon, Li, H., Shaffii, N., Shen, Q. (eds) *INCITE 2004 - International Conference on Information Technology in Design and Construction*, Langkawi, Malaysia, 167-182.
- Heesom, D., and Mahdjoubi, L. (2004). "Trends of 4D CAD applications for construction planning." *Construction Management and Economics*, February 2004, 22, 171-182, February 2004(22), 171-182.
- Jongeling, R., Olofsson T. (2006). "A method for planning of work-flow by combined use of location-based scheduling and 4D CAD." *Automation in Construction (article in press)*.
- Jongeling, R., Olofsson, T., and Emborg, M. (2004) "Modeling cast in place concrete construction alternatives with 4D CAD." In A. Dikbas, Scherer, R. (eds) *ECPPM 2004 - eWork and eBusiness in Architecture, Engineering and Construction*, Istanbul, Turkey, 109-116.
- Kenley, R. (2004) "Project micromanagement: practical site planning and management of work flow." In S. Bertelsen, Formoso, C.T. (eds) *IGLC-12, 12th Conference of the International Group for Lean Construction*, Helsingor, Denmark, 194-205.
- Koo, B., and Fischer, M. (2000). "Feasibility Study of 4D CAD in Commercial Construction." *Journal of Construction Engineering and Management*, 126(4), 251-260.

- Li, H., Ma, Z., Shen, Q., and Kong, S. (2003). "Virtual experiment of innovative construction operations." *Automation in Construction*, 12(5), 561-575.
- Mallasi, Z., and Dawood, N. (2002) "Registering Space Requirements of Construction Operations Using Site-PECASO Model." In K. Agger, Christiansson, P., Howard, R. (eds) *CIB w78 conference 2002 - Distributing Knowledge in Building*, Aarhus School of Architecture, Denmark, 1-8.
- McKinney, K., and Fischer, M. (1998). "Generating, evaluating and visualizing construction with 4D-CAD." *Automation in Construction*, 7(1998), 433-447.
- O'Brien, J. J. (1975). "VPM Scheduling for High-Rise Buildings." *ASCE J Constr Div*, 101(4), 895-905.
- Riley, D. R., and Sanvido, V. E. (1995). "Patterns of construction-space in multistory buildings." *Journal of Construction Engineering and Management*, 121(4), 464-473.



ELSEVIER

Automation in Construction xx (2006) xxx – xxx

AUTOMATION IN
CONSTRUCTION

www.elsevier.com/locate/autcon

A method for planning of work-flow by combined use of location-based scheduling and 4D CAD

Rogier Jongeling*, Thomas Olofsson

eBygg Center, Civil and Environmental Engineering, Luleå University of Technology, Luleå, Sweden

Accepted 22 March 2006

Abstract

There is a great potential to improve the flow of resources through locations on construction sites, termed work-flow. Current activity-based scheduling techniques do not provide adequate support for the planning of work-flow due to practical and methodological reasons. Location-based scheduling techniques provide a promising alternative to activity-based scheduling techniques for planning of work-flow. However, neither location-based nor activity-based scheduling techniques provide users with insight in the spatial configuration of scheduled construction operations. A technique that can provide this insight is 4D CAD in which 3D CAD models are combined with data from construction schedules. This article presents a process method for the planning of work-flow by combined use of location-based scheduling and 4D CAD. We suggest that a location-based approach to 4D CAD can improve the usability of the 4D CAD models for work-flow analyses. In addition, the article suggests that 4D CAD can enhance the value of location-based schedules.

© 2006 Elsevier B.V. All rights reserved.

Keywords: 4D CAD; Location-based planning; Work-flow

1. Introduction

Construction planners need to carefully design a process that ensures a continuous and reliable flow of resources through different locations in a project. The flow of resources through locations, termed work-flow, and the resultant ability to control hand-over between both locations and crews, greatly empowers the management of construction from the perspective of day-to-day management of activities [1]. There is a great potential to improve the work-flow on construction sites. A major in-depth study of seven Swedish construction projects reveals that only 15–20% of a construction worker's time is spent on direct work [2]. Approximately 45% is spent on indirect work (preparations, instructions, getting material, etc.). The remaining 35% is spent on redoing errors, waiting, disruptions, etc., i.e. a complete waste of time. We believe that managing the flow of work by improved planning methods can significantly contribute to the reduction of waste in the construction process.

The planning process in the construction industry is mainly focused on organizations and work breakdown, taking the work-flow and supply chain management more or less for granted. Today's commonly used technique to schedule the construction process is the activity-based critical path method (CPM). Construction planners decompose a project into activities that they associate with one or more building components (e.g. casting of concrete floor 3) that make up the project. Each activity is included in a bar chart and a network that describe the proposed schedule of a project. This practice builds on the assumption that progressive subdivision of work-scope eventually turns into specification of how construction tasks should be executed [3]. Some construction planners use the CPM method to integrate the product (i.e. what is to be done) with the process (i.e. how it is done), but this leads to very detailed CPM schedules that are difficult to use and to update [4]. As a result, detailed schedules are often not updated during a construction process and thereby lose their value as an instrument to plan and control work-flow. Kenley [1] illustrates the difficulties with the manipulation of information in a detailed schedule with the following example: a 50-floor building with 10 apartments involving 50 activities necessitates

* Corresponding author. Tel.: +46 702702543; fax: +46 920491913.

E-mail address: rogier.jongeling@ltu.se (R. Jongeling).

managing 25,000 individually scheduled activities. Such a schedule is possible to set up, but difficult to analyze and manipulate.

Another difficulty with the current use of the CPM scheduling method for construction planning is related to the spatial configuration of a project. Construction projects have unique spatial configurations and the spatial nature of projects is very important for planning decisions [5]. The CPM schedule does not provide enough information pertaining the spatial context and complexities of the project components [6]. Therefore, to identify the spatial aspects of a project, users must look at 2D drawings and conceptually associate the building components with the related activities from the CPM schedule. Interpreting detailed CPM schedules in combination with 2D drawings can be a cumbersome process, which limits the possibility to identify opportunities, problematic sequences or mistakes. Different project members may develop inconsistent interpretations of the schedule when viewing the CPM schedule and 2D drawings. This in turn makes effective communication among project participants difficult.

A promising approach that combines planning data and spatial data in one environment is 4D CAD. 4D modelling is a process method in which 3D CAD models are visualized in a 4-dimensional environment. 4D CAD models allow project planners to simulate and analyze what-if scenarios before commencing work execution on site [7]. Planning supported by visual analyses of 4D CAD models is considered more useful and better than traditional planning [8,9], but does not provide insight in the flow of resources through specific locations in a construction project. Research and application of 4D CAD to date has been dominated by the linkage of 3D CAD building components with activity-based planning approaches, such as CPM schedules. The difficulty of applying flow-based thinking in such models arises from the problem that the models are based around discrete activities. An additional problem is the fact that 4D CAD models often are not organized according to a location-based logic, which further constrains the application of flow-based thinking.

This article suggests that location-based scheduling provides a promising alternative to activity-based planning approaches for planning of work-flow with 4D CAD. A location-based approach to 4D CAD could also improve the usability of the 4D CAD models for work-flow analyses. In addition, the article suggests that 4D CAD can enhance the value of location-based schedules. The article first discusses location-based scheduling techniques and 4D CAD in further detail, after which results from a case study are presented in which both methods are combined. The article continues by proposing a process method for the combined use of location-based scheduling and 4D CAD. This section is followed by discussions and recommendations for further research.

2. Scheduling methods for construction

Two main methodologies for scheduling construction work can be identified: activity-based scheduling and location-based scheduling. As noted in the introduction of this article, activity-

based scheduling is the dominant scheduling method in construction today and is, as a consequence, the basis for today's 4D CAD models. Activity-based scheduling methods are well-suited for processes that are dominated by complex and sequential assemblies of pre-fabricated components, involving discrete activities on a predestined discrete location. However, many construction projects have a different character. They typically consist of large amounts of on-site fabrication, which involves continuous or repetitive work at different locations. These characteristics of construction align more closely with location-based scheduling [1].

2.1. Location-based scheduling

Location-based scheduling is not a new concept and has been a research issue for many years. Practical use in construction has been limited, mainly due to the strong tradition of activity-based planning and the absence of software packages that support location-based planning. Research and development regarding the location-based scheduling method has been carried out since the 1940s and variations of the method appear in literature under different names, such as 'Line-of-Balance', 'Flowline', 'Construction Planning Technique', 'Vertical Production Method', 'Time–Location Matrix Model', 'Time–Space Scheduling Method', 'Disturbance Scheduling', and 'Horizontal and Vertical Logic Scheduling Logic for Multi-Story Projects' [1,10,11]. In this article we adopt the Line-of-Balance scheduling technique as an example of a location-based scheduling method.

Line-of-Balance is a visual scheduling technique that allows the planner to explicitly account for flow of a project [12]. Line-of-Balance uses lines in diagrams to represent different types of work performed by various construction crews that work on specific locations in a project. Examples of Line-of-Balance diagrams that are created with the commercial software package DYNAPROJECT are shown in Fig. 1.

Scheduling a project with Line-of-Balance begins by breaking down the project in physical sections (i.e. locations), such as for example 'location 1' included in 'building A', which is part of 'project X'. Creating tasks in the schedule (i.e. lines) is done by using items from the bill of materials or cost estimate in a project [13]. For example, from the bill of quantity item 'concrete floor 1' the following tasks are derived: 'install shoring', 'install formwork', 'install reinforcement', 'pour concrete' and 'remove formwork and shoring'. In this way a specification is directly made for the amount of work per location in a project for a construction crew. Based on these quantities and task description, the required crew size can be determined. The bill of quantity items and cost estimate define what should be done and the tasks in the Line-of-Balance schedule define how this is done. As noted in the Introduction section of this paper, this relation is often not explicitly made in CPM schedules [3] and when done so it leads to very detailed and unmanageable schedules [1,4].

Two main principles are used to minimize the deviations listed in Fig. 1 and to plan for work-flow with Line-of-Balance diagrams: synchronization and pacing.

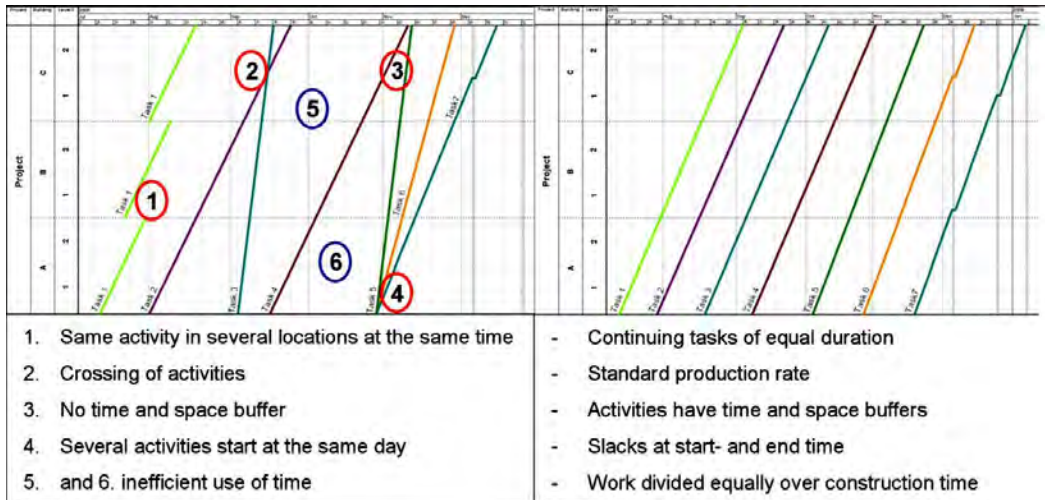

Fig. 1. Examples of Line-of-Balance diagrams. Locations are represented on the Y -axis and project time on the X -axis. The lines represent construction operations by crews. (Left) Common deviation types (nos. 1–6) in a Line-of-Balance diagram. (Right) Typical solutions to deviations in a Line-of-Balance diagram.

- Synchronization means that planners aim to achieve a similar production rate for all activities. A synchronized schedule can be identified by parallel lines that show a constant time–space buffer between different tasks.
- Pacing means that the activities are scheduled to continue from one location to another without interruptions.

Fig. 1 shows the most common deviation types that can be identified by using Line-of-Balance diagrams. These deviation types indicate scheduling mistakes and opportunities to plan for a stable and continuous flow of work through locations of a project. Fig. 1 summarizes the deviation types in one Line-of-Balance diagram and for a more comprehensive overview of deviations we refer to Seppänen and Kankainen [12]. Identifying deviations that can affect the work-flow and manipulating the schedule to address these issues is much easier and more feasible compared to the use of activity-based scheduling methods, such as CPM.

It appears that the Line-of-Balance technique entails useful mechanisms for the planning of work-flow. However, the method does not explicitly address the spatial configuration of activities. In order to identify what building components are related to an activity, users still have to look at 2D drawings to understand the spatial implications of an activity. This process is prone to errors due to the fact that different users may develop inconsistent interpretations of how activities are related to building components shown on different 2D drawings. The locations in the Line-of-Balance diagram provide some spatial information, but these are abstract representations of the real world. Spatial configuration of a project is often much more complex than the hierarchical location structure of a Line-of-Balance diagram.

In summary, Location-based scheduling based on the Line-of-Balance technique appears to provide better characteristics to

plan work-flow, compared to activity-based scheduling techniques. Combining Line-of-Balance with 4D CAD could add spatial insight in the planning of work-flow that could add to the quality of the process design. We first discuss the current practice regarding 4D CAD before combining the Line-of-Balance technique with 4D CAD.

2.2. 4D CAD models today

4D CAD models are typically created by linking building components from 3D CAD models with activities that follow from CPM schedules. Building components that are related to an activity, which is ongoing, are highlighted. The 4D CAD model provides the user with a clear and direct picture of the schedule intent and helps to quickly and clearly communicate this schedule to different stakeholders in a project. This is the main area in which 4D CAD currently is used; to communicate schedule intent, often at a macro-level, in a project.

The use of 4D CAD to plan work-flow on site is very limited. The limited use is due to several reasons. First of all, planning of work-flow with 4D CAD models that are based on CPM schedules requires detailed 4D CAD models. This implies two practical limitations. A detailed 4D CAD model requires a detailed CPM schedule, which in its turn is difficult to manipulate. The 4D CAD models themselves are also difficult to update to reflect the latest version of the schedule. Therefore most of today's 4D CAD models are made once and not updated.

Secondly, the 3D CAD models on which most of today's 4D CAD models are based, are limited to building components. Building components are in many cases useful and sufficient as an information carrier in a 4D CAD model that is used to communicate a master schedule. However, planning of work-

Table 1
Advantages and limitations of today's scheduling methods to plan work-flow

Method	Advantage	Limitation
CPM and 2D drawings	<ul style="list-style-type: none"> – Common and accepted format. – Relatively cheap and powerful software available. 	<ul style="list-style-type: none"> – Planning work-flow is difficult and results in very detailed schedules. – Spatial configuration of an activity difficult to plan and communicate.
LoB and 2D drawings	<ul style="list-style-type: none"> – Managing activities (i.e. lines) requires little effort. – Explicit support for planning of resource-flow through locations. – Powerful software available. 	<ul style="list-style-type: none"> – Limited support to plan and communicate the spatial configuration of an activity. – Relatively unknown method.
CPM and 4D CAD	<ul style="list-style-type: none"> – Provides spatial insight in the planning of work-flow. 	<ul style="list-style-type: none"> – Inherent to limitations of CPM. – Many 4D CAD models are limited to the use of 3D building components and do not include components related to work-flow. – Relatively unknown and developing method.

flow with a 4D CAD model requires additional objects that are not included in most of today's 3D CAD building models. A concrete slab for example that is poured in several sections requires one 3D object for every concrete pour. In most cases the whole slab comes as one object in the 3D CAD building model thereby limiting the visualization of work-flow in 4D CAD. Further detailing is needed of the building model to suit the level of abstraction for simulation of the construction process. Research by Akbas [5] demonstrates that this process can partly be automated by defining sub-systems in a 4D model (e.g. a concrete slab) for which users define crew parameters and geometric work-locations. Triangle meshes are used to simulate and visualise the work-flow of construction crews in a 4D CAD model.

Thirdly, many aspects of construction activities are not directly related to building components, which further complicates the use of 4D CAD models for the planning of work-flow.

Casting a concrete slab for example requires, among other things, temporary structures in the form of shoring and formwork. The activities in the casting process also require spaces for crews to work and to temporarily store and manage materials and equipment items that are used. These aspects affect the flow of work on construction sites, but are difficult to include in 4D CAD models.

In summary: 4D CAD models provide planners with a spatial insight in the scheduling process of construction operations which is not provided by using 2D drawings in combination with CPM schedules or LoB diagrams. The possibility to plan work-flow with today's common 4D CAD models is limited and requires a different approach to creating and managing 4D CAD models.

2.3. Summary of scheduling methods

The main advantages and limitations of today's CPM and Line-of-Balance scheduling methods to plan work-flow are summarized in Table 1.

The combination of location-based planning by applying the Line-of-Balance technique in combination with 4D CAD could be a promising method in which the strengths of both methods could reinforce each other. To explore the possible benefits and shortcomings of this combined method a case study was set up as part of a course in Virtual Construction at Luleå University of Technology, Sweden. We worked together with a number of M.Sc. and PhD. students and experts from the industry during this course in which both methods were combined and applied in a virtual construction project. In the next section the method and main results are presented.

3. Line-of-Balance combined with 4D CAD — case study

3.1. Introduction

The case study is based on a 3D model of a planned cultural centre in the city of Luleå, Sweden, see Fig. 2. At the time of our research, there was a 3D model available from an architect and the tender for construction work was in

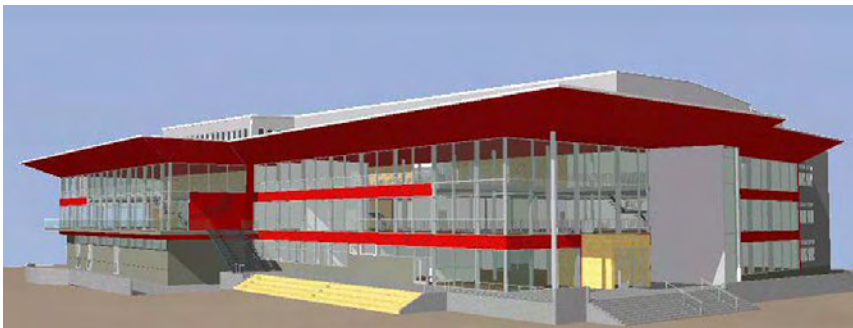

Fig. 2. A 3D CAD model of the cultural centre in the city of Luleå, Sweden.

preparation. Where possible the course work was based on actual data from the project, but most of the scheduling data and construction methods were assumed for exploratory purposes.

The building consists of a two-storey underground parking garage and a superstructure that contains, among other things, a library and a concert hall. The work was limited to scheduling with the Line-of-Balance technique and simulation with 4D CAD of the superstructure, excluding the roof. This included the scheduling and simulation of floors 3, 4, 5 and 6 of the building, shown in Fig. 2. The superstructure consists of cast-in-place concrete slabs that are supported by prefabricated concrete columns and walls. In addition to bearing walls and columns, each floor contains non-bearing walls and interior objects, such as railings, fittings, etc.

3.2. Preparation of location-based 3D CAD model

The architectural CAD model, received from the architect, was transferred from ArchiCAD to AutoCAD Architectural Desktop (ADT) via an IFC2x file [14]. The architectural model was prepared in ADT for use in combination with the Line-of-Balance diagrams and for the subsequent use in Commonpoint 4D (CP4D). CP4D is a software used to link schedule data to 3D CAD components. An important step in preparation of 3D CAD models for 4D simulation is the definition of locations. The location-hierarchy of the CAD model and the Line-of-Balance diagram had to be identical to be able to benefit from the combined use.

The casting work on each slab was divided into seven sections, shown in Fig. 3. This required the splitting of the single slab from the architectural model into seven independent objects. Other objects, such as bearing and non-bearing walls, were also divided into seven sections, but these components did not exactly follow the section boundaries that were set up for the concrete slab, due to their supplied component sizes. Certain

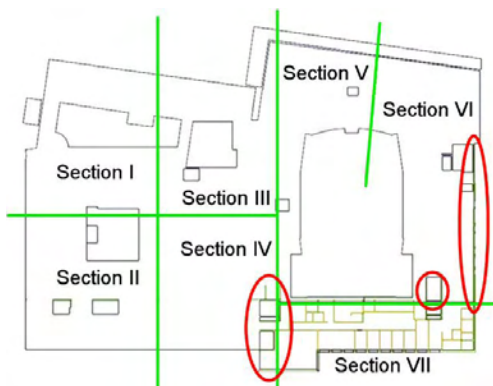

Fig. 3. Top view of floor 4 in the 3D CAD model of the cultural centre. The architectural slab is split into seven sections in which the slab is cast. Certain objects (e.g. bearing walls) do not exactly follow the section boundary and overlap into other sections, marked by circles in the figure.

Table 2

Scheduled activities for the construction of the bearing structure of the cultural centre

Task in DYNAPProject	Layers and objects in ADT and CP 4D	Description and work order
Pillars and dividing walls	Columns and bearing walls	The dividing walls (bearing walls) are part of the building framework and support the slab, together with the pillars (columns). The walls and columns are prefabricated elements.
Formwork	Slab and space	Formwork is needed to cast the slabs and is installed after the pillars and dividing walls are put in place.
Reinforcement	Slab	Reinforcement for the slabs is installed on the formwork before the slabs are cast
Concreting	Slab	Slabs are part of the building framework and are cast after the formwork and reinforcement are installed. Slabs are supported by dividing walls (bearing walls) and pillars (columns).

prefabricated walls for example could not be split and, as a result, overlapped other sections. This is illustrated in Fig. 3 in which walls from Section VII overlap in Section IV and Section VI, marked by circles.

A set of CAD-layers was created in ADT according to the defined locations for the project on which all 3D CAD objects were put. A quantity take-off was made from the 3D CAD model per location, which was exported to MS Excel. In MS Excel the quantity data was prepared for import to DYNAPProject in which the quantities were used as a basis for the Line-of-Balance scheduling.

3.3. Scheduling with the Line-of-Balance technique

The scheduling process in DYNAPProject started with the creation of a location-hierarchy for the Line-of-Balance diagram. This diagram followed the exact same structure as the defined locations in the 3D CAD model. The quantity data from the 3D CAD model was subsequently imported to the DYNAPProject after which the definition of activities started.

Table 2 includes a description of the activities related to the building framework. These activities were followed by installation of windows and non-bearing walls, after which the finishing work was scheduled, such as painting, covering floors and the installation of fittings.

Each activity is based on a quantity take-off item in which certain items can be the basis for several activities. The quantity take-off item 'Slabs' for example is used to define the activities for formwork, reinforcement, concreting and floor covering work.

Schedule data was exported to MS Excel after the Line-of-Balance diagram was optimized. The schedule data was then prepared for import to CP4D. The exported schedule data included one activity for every task and for every location. The work-flow which was manageable with twelve lines in the Line-of-Balance schedule resulted in a CPM schedule of over three hundred activities from which it was difficult to obtain an

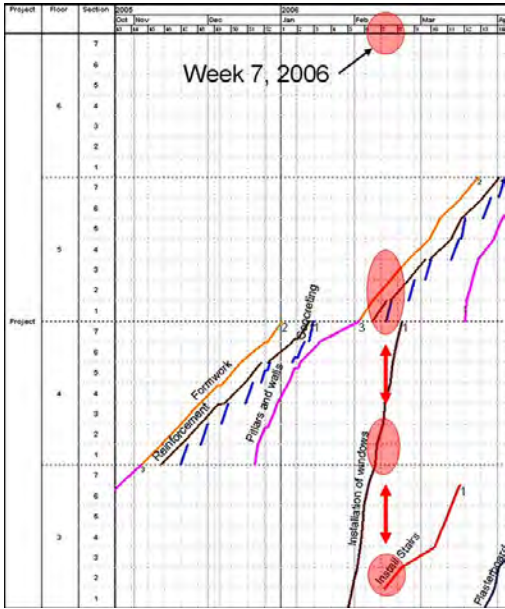

Fig. 4. First version of the Line-of-Balance diagram for the cultural centre. By using the 4D CAD model that is based on this Line-of-Balance diagram we were able to detect a number of scheduling issues that we did not detect in the diagram.

overview while linking the activities to 3D CAD components in CP4D.

3.4. Simulation of Line-of-Balance diagrams with 4D CAD

The 3D CAD components were exported from ADT as VRML files and imported to CP4D. 4D CAD simulations could be made after the linking process was completed. However, the 4D model was not complete at this point. The 3D CAD components from the building model were not suitable or sufficient to visualize certain activities. The installation of fittings for example required different components than building components, such as walls and slabs. Other activities also required activities that could show ongoing work in a location, rather than ongoing work on a building component. For this reason space objects were created in 3D CAD for every location in the Line-of-Balance diagram that also were imported to CP4D.

The Line-of-Balance diagram was created according to a number of milestones. The diagram was subsequently optimized against the following work-flow related factors, by means of pacing and synchronization:

- Minimizing variation in resource use.
- Ensuring sufficient time and space between different trades.
- Minimizing discontinuities in the work of a trade.
- Avoiding simultaneous work of the same trade at different locations.

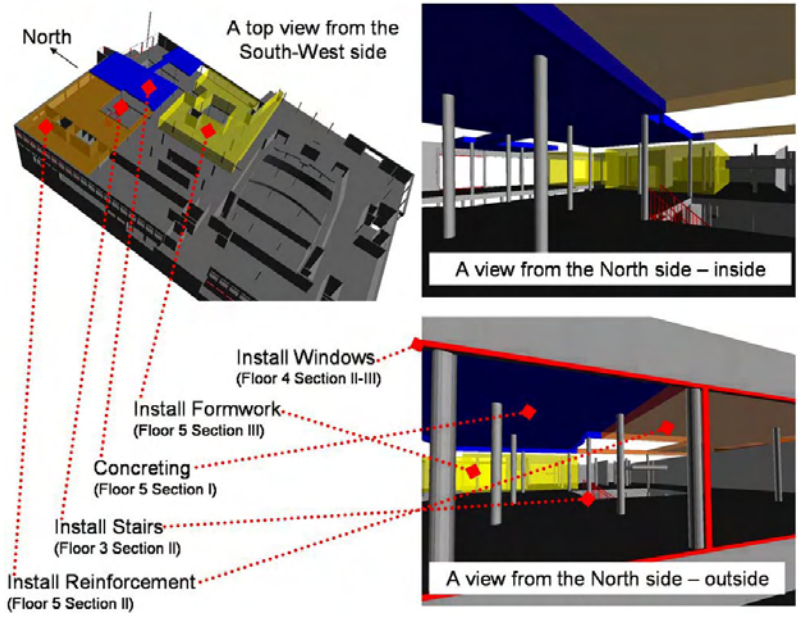

Fig. 5. Three different screen captures of the same scheduled construction tasks at the beginning of week 7 2006 in the 4D CAD model of the cultural centre.

3.5. Results from 4D CAD simulations

The first scheduling session resulted in a Line-of-Balance diagram, of which a screen capture of a part of the diagram is included in Fig. 4. The figure shows the following sequential tasks: ‘install formwork’, ‘install reinforcement’, ‘concreting’, ‘erect pillars and walls’, ‘installation of windows’, ‘install stairs’ and ‘plasterboard walls’. The Line-of-Balance diagram shows that most tasks are continuous activities per floor, but that the work is interrupted when crews move to a higher floor. The reinforcement task shows two minor interruptions on floor 5 and was later adjusted to create a continuous flow. The concreting tasks are scheduled per section, due to the fact that the casting work cannot be executed as a continuous flow for a whole floor.

When the schedule was simulated in 4D CAD a few planning issues were identified that did not become apparent from the Line-of-Balance diagram. From the simulation it became clear that construction tasks at the beginning of week 7 in 2006 were planned with too little consideration of required work- and buffer-space between different activities. The concurrent tasks at this point in time are marked by circles in Fig. 4.

Fig. 5 includes screen captures from the 4D CAD model which shows that many different activities are concentrated around Section I–III on different floors of the building. Work on the building structure is ongoing on floor 5 in Sections I–III and windows are installed at the same time on floor 4 in Sections I and II. In addition, stairs are installed on floor 3 in Section II. This concentration of activities is not apparent in the Line-of-Balance diagram and could have disrupted the work-flow of construction crews. The use of 4D CAD in this case was beneficial as it provided a spatial insight in the Line-of-Balance

diagram. After the 4D CAD simulations the tasks for the installation of windows and stairs were rescheduled to a later point in the project and evaluated by updating and simulating the 4D CAD model.

4. Proposed process method

Based on the findings from the case study and theoretical studies we propose the following process model for the planning of work-flow in construction, which includes model-based methods for cost estimation, production planning and simulation. The process model is based on the combined use of location-based scheduling and 4D CAD.

The process is described using the IDEF0 technique, see Fig. 6. IDEF0 is a structured technique that combines graphical language with text-based descriptions [15]. Each process in a system is represented with a rectangular box and the relationships of the boxes are shown by arrows. Four types of arrows can be identified: Arrows that enter a box from the left side are the inputs for a process. Arrows that leave box from the right side are the outputs of a process. The arrows that enter a box from the bottom side are the mechanisms of a process and the arrows entering a box from the top are the controls of a process.

Five main processes are identified within the planning process. The first process concerns the preparation of location-based 3D CAD models. The definition of locations is an important step in the process as it is the basis for the 3D CAD model, the Line-of-Balance diagram and 4D CAD model, but also for the location-based quantitative take-off and cost estimation. The preparation of location-based 3D CAD models also includes the modelling of space objects that can be used to represent activities in the subsequent 4D CAD model that are

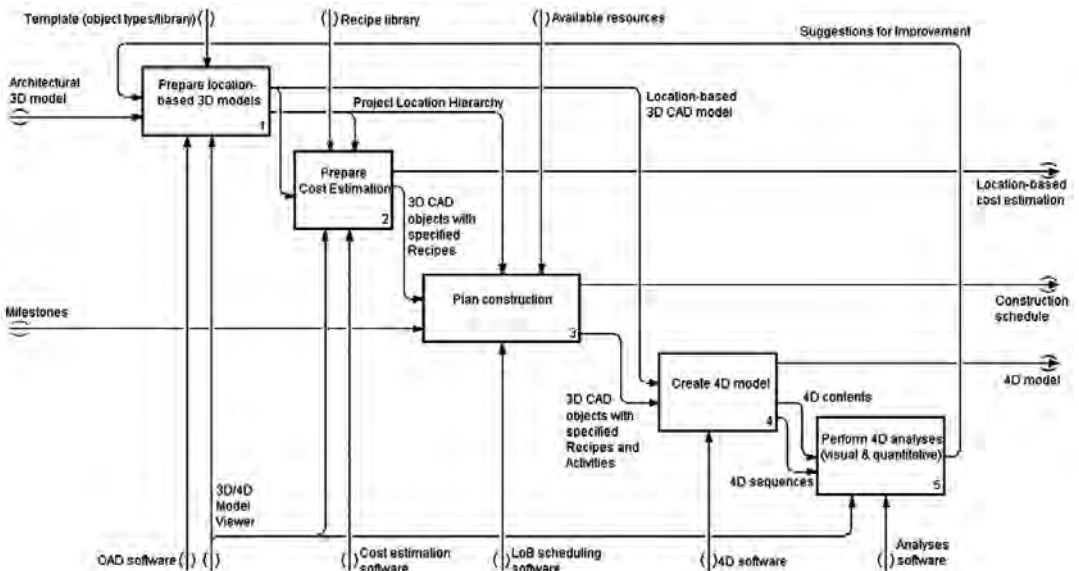

Fig. 6. Proposed process model for combined use of location-based planning and 4D CAD.

indirectly related to building components or that represent the work in certain construction zones.

The second process is the cost estimation process. Input for this process is the location-based 3D CAD model (i.e. location-based bill of quantities). The cost estimation is made by defining recipes for building components. Each recipe includes methods (i.e. a number of tasks) and resources (e.g. man hours) needed for a building component. A recipe for a cast-in-place concrete wall for example includes methods such as ‘install formwork side A’, ‘install reinforcement’, ‘install formwork side B’, ‘cast concrete’ and ‘remove formwork’. For each of these tasks it is known, based in historic data, how much resources are required. The output of the cost estimation process is a location-based 3D CAD model with recipes specified for each 3D CAD object. This model is the input for the third process, which is the planning process with the Line-of-Balance technique.

The third process involves the definition of tasks in the Line-of-Balance diagram by using the methods that are defined in the 3D CAD model during the cost estimation process. The Line-of-Balance diagram is structured according to the exact same location-hierarchy as the 3D CAD model and cost estimation. By using the Line-of-Balance technique planners can optimize the flow of resources through locations in a project by synchronizing and pacing the scheduled tasks in the diagram.

The results of the third process are used in the fourth process in which 4D CAD models are created. The 4D modelling process includes linking of tasks from the schedule to building objects and spaces from the 3D CAD model. This process can be automated with appropriate mechanisms as each task is associated in the schedule with objects from the 3D CAD model. The 4D modelling process results in 4D simulations and 4D content. 4D content is defined as quantitative data extracted from 4D models to support 4D-based-analysis of construction planning information [16].

Visual and quantitative analyses are made of the 4D CAD model in the fifth process which can result in suggestions for improvement for the 3D CAD model or the Line-of-Balance diagram. This is an iterative process in which processes one to five are repeated until a construction schedule emerges that ensures a continuous and reliable flow of resources through different locations in a project.

5. Discussion and further research

The case study shows that the combined use of location-based scheduling and 4D CAD is a promising mechanism to plan for work-flow. The specific planning decisions and structure of the 3D CAD model and Line-of-Balance diagram of the presented case study are hypothetical, but show a planning process that does not occur in today’s construction planning. Reasoning, such as analyzing distances between different tasks and rerouting tasks, is done in actual production where there is a limited opportunity to change construction execution strategies, especially in cases where much of the work is handed out to subcontractors. This leads to waste in the form of waiting by crews, rework and disruptions. We believe that

managing the flow of work by combining 4D CAD with location-based scheduling methods can significantly contribute to the reduction of waste in the construction process.

The Line-of-Balance technique allows planners to quickly gain insight in the flow of resources through locations in projects. The visual representation of scheduled tasks requires minimal effort to manipulate a schedule, when for example the work of a crew has to be rerouted through different locations of a project. Compared to activity-based methods, such as CPM, the Line-of-Balance method facilitates the planning for work-flow. The method can also be a good basis for the planning of work-flow with a 4D CAD model as a result of the integration of schedule data and 3D CAD object data. This tight integration addresses some of the current limitations related to the creation and manipulation of a 4D CAD model and facilitates the process of rescheduling and updating a 4D CAD model.

The 4D CAD model is a valuable supplement to the Line-of-Balance diagram as it allows users to quickly and clearly gain insight in the spatial configuration of scheduled activities. The 4D CAD model of the case study showed for example the concentration of different activities in one corner of the building on multiple floors, resulting in a lack of work-space and hazardous conditions for crews to perform safe and productive work. This concentration did not become apparent from the Line-of-Balance diagram, but could be detected by using the 4D CAD model that was based on the Line-of-Balance diagram. The case study also showed that the use of a 4D CAD model provides insight in the relation between the location-hierarchy and building components from the 4D CAD model. Certain types of building objects partially overlapped multiple locations. This insight could not be gained from the Line-of-Balance diagram, but became clear from the 4D CAD model. The combined use of location-based planning and 4D CAD reinforces both methods and forms a promising toolset to plan for a reliable and continuous flow of resources through locations in a project.

The proposed planning method is best initiated in the early stages of a project. Project actors have to agree at this stage on a hierarchical decomposition of the project into locations by which the 3D CAD models, cost estimation, construction planning and 4D CAD models will be structured. Furthermore, a tighter integration between design and production planning in the early stages of a project creates opportunities for constructability analysis, prefabrication of components and selection of proper work methods with regard to the available work space. Early definition of these locations can also facilitate the data transfer between different types of systems that are used in the design, cost estimation and planning process. The case study showed that the proposed method can be implemented by using a number file transfers between different commercial software systems. The data transfer- and data modelling process can be streamlined and automated by standardizing the data content and by using the same source data, such a shared project database. We believe that dedicated software packages for a number of different professionals (i.e. CAD consultants, cost estimators, construction planners, 4D modellers, etc) should be

integrated, rather than developing a single software system to perform all tasks.

Although the Line-of-Balance method is a mechanism to plan how a construction task will be performed, it does not provide the user with a clear picture whether a task can be performed. Examples of prerequisites for successful execution of a task are [17]: the availability of information, equipment, space, material and labour. It is also important that the work by the previous crew is completed. Managing these conditions implies continuous monitoring and manipulation of schedules and 4D CAD models. Mechanisms should also be available that allow planners and crews to manage the prerequisites for an activity throughout the combined use of location-based scheduling and 4D CAD models. The presented case study is limited to the planning for work-flow and does not address the control of work-flow. Further research is required in which the principles and criteria for efficient and effective work-flow management are studied, as for example suggested by Koskela [17], in relation to the use of location-based scheduling and 4D CAD. Kenley [1] suggest the use of Line-of-Balance schedules for micro-management of work-flow on site by explicitly addressing the requirements from the site personnel. It is suggested to further explore the concept of micro-management based on Line-of-Balance schedules in relation to the use of 4D CAD models.

The results from a 4D CAD model are currently mainly used for graphical analyses. When construction planners visually evaluate the 4D CAD model, they may or may not detect constructability issues, such as time-space conflicts, that can jeopardize the work-flow. Planning supported by visual analyses of 4D CAD models is considered more useful and better than traditional planning methods, but does not take advantage of the quantitative data contained in 4D CAD models [16]. Further research is required to study what 4D content can be extracted from 4D CAD models and how this can be used for quantitative analyses in the planning and control process for work-flow. One obvious extension is the management of the supply chain to the building site. Since the proposed production planning process connects the building objects with location and time, material delivery schedules can be automatically produced. These schedules can be used for procurement and call orders from suppliers of components and material to the building site to get a better integration of the supply chain of materials with the work-flow at the building site.

In the case study it was illustrated how an architectural 3D CAD model can be prepared for the simulation of construction operations in 4D CAD. The preparation process entailed the definition of locations and the modelling of objects to represent locations. The locations were subsequently used to represent tasks with an indirect relation to building components, such as the installation of formwork. Although the use of space objects is considered a promising technique to represent the location of a task, it is not clear what type of space is represented. The space usage on construction sites can be classified into different types of spaces. Akinci et al. [18] identify for example the following different types of spaces and models these space-types in a 4D CAD model: building component space, material space, labour

space, equipment space, space for temporary structures and hazardous space. We believe that the management of work-flow should include the management of different space-types, in addition to the management of resource-flow through locations in a project. Space is in this respect considered as a resource that is related to a location and a task in a project. Currently, Line-of-Balance schedules concentrate on the scheduling of crew locations and do not specify the types of space that a location includes (e.g. equipment space, labour space and material space) or how the use of one location results in space requirements for another location. An activity on a floor might for example create a hazardous situation for the execution of construction work in a location on a floor beneath. We suggest further research to study the use of the Line-of-Balance technique in combination with 4D CAD to plan and manage space use as part of the work-flow management on construction sites. The work-flow management should not be limited to avoiding discontinuities and time–space problems that can negatively affect the work-flow, but should also include the identification of scheduling opportunities that can benefit the work-flow.

References

- [1] R. Kenley, Project micromanagement: practical site planning and management of work flow, in: S. Bertelsen, C.T. Formoso (Eds.), IGLC-12, 12th Conference of the International Group for Lean Construction, Helsingor, Denmark, 2004, pp. 194–205.
- [2] P.-E. Josephson, Byggfel och andra icke värdeadderande aktiviteter, Byggkostnadsforum seminar: från no-tech till hi-tech, Stockholm, Sweden, 2005.
- [3] G. Ballard, G. Howell, An update on last planner, in: J.C. Martinez, C.T. Formoso (Eds.), 11th International Group for Lean Construction Conference, Virginia Tech, Virginia, USA, 2003.
- [4] B. Huber, P. Reiser, The marriage of CPM and lean construction, in: J.C. Martinez, C.T. Formoso (Eds.), 11th International Group for Lean Construction Conference, Virginia Tech, Virginia, USA, 2003.
- [5] R. Akbas, Geometry-based modeling and simulation of construction processes, PhD Thesis, Department of Civil and Environmental Engineering, Stanford University, 2004.
- [6] B. Koo, M. Fischer, Feasibility study of 4D CAD in commercial construction, *J. Constr. Eng. Manag.* 126 (2000) 251–260.
- [7] Z. Mallasi, N. Dawood, Registering space requirements of construction operations using site-PECASO model, in: K. Agger, P. Christiansson, R. Howard (Eds.), CIB w78 conference 2002 — Distributing Knowledge in Building, Aarhus School of Architecture, Denmark, 2002, pp. 1–8.
- [8] M. Fischer, T. Hartmann, E. Rank, F. Neuberger, M. Schreyer, K. Liston, J. Kunz, Combining different project modelling approaches for effective support of multi-disciplinary engineering tasks, in: P. Brandon, H. Li, N. Shaffii, Q. Shen (Eds.), INCITE 2004 — International Conference on Information Technology in Design and Construction, Langkawi, Malaysia, 2004, pp. 167–182.
- [9] D. Heesom, L. Mahdjoubi, Trends of 4D CAD applications for construction planning, *Constr. Manag. Econ.* 22 (February 2004) 171–182.
- [10] W.E. Mohr, Project Management and Control 5th edition, Department of Architecture and Building, University of Melbourne, Melbourne, Australia, 1991.
- [11] R.B. Harris, P.G. Ioannou, Scheduling projects with repeating activities, *J. Constr. Eng. Manag.* 124 (1998) 269–278.
- [12] O. Seppänen, J. Kankainen, Empirical research on deviations in production and current state of project control, in: S. Bertelsen, C.T. Formoso (Eds.), IGLC-12, 12th Conference of the International Group for Lean Construction, Helsingor, Denmark, 2004, pp. 206–219.

- [13] J. Kankainen, O. Seppänen, A Line-of-Balance based schedule planning and control system, in: J.C. Martinez, C.T. Formoso (Eds.), 11th International Group for Lean Construction Conference, Virginia Tech, Virginia, USA, 2003.
- [14] IAI, "International alliance for interoperability", [online] Available at: <URL: <http://www.iai-international.org>>, [Accessed August 29, 2005].
- [15] A.M. Tanyer, G. Aouad, Moving beyond the fourth dimension with an IFC-based single project database, *Autom. Constr.* 14 (2005) 15–32.
- [16] R. Jongeling, J. Kim, C. Mourgues, M. Fischer, T. Olofsson, Quantitative analysis using 4D models — an explorative study, in: C. Park (Ed.), First International Conference on Construction Engineering and Management, Korea Institute of Construction Engineering and Management, Seoul, Korea, 2005.
- [17] L. Koskela, Management of production in construction: a theoretical view, in: I.D. Tommelein, G. Ballard (Eds.), *IGLC 7: Proceedings of the Annual Conference of the International Group for Lean Construction*, University of California, Berkeley, CA, USA, 1999, pp. 241–252.
- [18] B. Akinci, M. Fischer, J. Kunz, Automated generation of work spaces required by construction activities, *J. Constr. Eng. Manag.* 128 (2002) 10.

Paper IV

APPLICATION OF LINE-OF-BALANCE AND 4D CAD FOR LEAN PLANNING

Authors

Anders Björfot ^a and Rogier Jongeling ^a

Affiliation

^a PhD Student, Luleå University of Technology, Civil and Environmental Engineering, Division of Structural Engineering, Luleå, Sweden

Accepted for publication in Construction Innovation (July 2006)

Abstract

This paper suggests the application of the Line-of-Balance scheduling technique in combination with a 4D CAD workspace model as a method to improve the management of the flow of resources through locations in construction projects. Current scheduling methods fail to consistently manage work flow. The lack of work flow planning can disrupt the construction process, leading to waste. The proposed methods are applied to a case study of a multi-storey timber housing project. It is shown that many of the problems experienced in the actual construction process, quickly become evident from an analysis of a relatively simple Line-of-Balance schedule. Furthermore, the 4D CAD model, used to visualize the flow of work during construction, provides additional insight in the scheduling of construction activities, such as work space availability and partial overlap of work spaces. In the article we refer to the guiding principles from lean construction in relation to virtual design and construction methods, such as simulations with 4D CAD. Additional research and studies of practical applications are suggested to facilitate the combination of principles from lean construction with virtual design and construction methods.

Keywords

Line-of-Balance, 4D CAD, construction planning, timber housing construction, work flow

1. Introduction

Multi-storey timber housing construction has in recent years seen an increase in use on the Swedish construction market. There are currently a number of construction methods available for these types of buildings, ranging from traditional methods to prefabrication using elements and volumes. Production of multi-storey timber housing often involves the use of both factory and on-site production. Factory production of timber housing components and prefabricated houses are well-developed in Sweden by utilizing automated machinery and process control systems. On-site timber frame construction is not developed to the same degree, leading to an inefficient on-site construction process (Björnfot and Stehn, 2005).

Some of the problems related to on-site construction are directly caused by a deficient design process and poor prefabrication strategies, which commonly results in inefficient work operations and difficulties to control the work progress (Björnfot and Stehn, 2005). In addition there are a number of problems (e.g. rework, quality issues, delays, forced production) that are directly, or indirectly, caused by poor planning and insufficient control mechanisms of the construction process. Insufficient planning in addition to deficient product design may lead to work flow uncertainty and increased variability of crew productivity, possibly disrupting the construction process (Tommelein et al., 1999).

A recent Swedish study of non-value adding work on the construction site indicated that up to 35% of work performed is waste, e.g. waiting, rework, movement (Josephson and Saukkoriipi, 2005). Hence, there appears to be a great potential to improve the flow of resources through locations in construction projects. Improved planning methods for work flow (the flow of resources, such as crews and materials through locations in projects) can make the flow of resources more reliable and continuous through the construction site. Improved work flow reliability provides a more efficient production process, less wasted effort and rework, and better matching of resources to tasks (Ballard, 2000). Planning and control over construction operations and a design process taking constructability issues into consideration are necessary steps in improving quality and productivity of the construction process.

1.1 Aim and scope

The aim of this paper is to evaluate the application of two increasingly used process design methods for improved planning of construction operations in a

case study project. The first method is the Line-of-Balance (LoB) scheduling technique that is used to evaluate the construction planning of the case study project from a work flow perspective. The second method concerns simulation with 4D CAD, which is used to analyze the flow of scheduled construction operations through work locations of the case study project.

The paper first introduces the LoB scheduling technique and 4D CAD simulation after which both methods are applied to a multi-storey housing project. The article continues by discussing the benefits and limitations of both methods, based on results from the case study. This section is followed by a discussion of the benefits of the combined use of scheduling and simulation with LoB and 4D CAD. The paper concludes with a discussion and suggestions for further research.

2. Production planning and simulation

All events during a construction project cannot be perceived by planning alone. However, relevant planning of resources and activities can allow complex projects to be brought under control (Kenley, 2004). Control of activities (i.e. work tasks), trades (i.e. work teams and subcontractors), and resources (e.g. machinery and tools) on the construction site is of vital importance for the management of site production in construction (Heinrich et al., 2005). Construction planners need to carefully design a process that ensures a continuous and reliable flow of resources through different locations in a project (Jongeling et al., 2005). The flow of resources through locations and the resultant ability to control hand-over between both locations and crews, greatly empowers the management of construction from the perspective of day-to-day management of activities (Kenley, 2004).

2.1 Managing production through Line-of-Balance (LoB)

As a scheduling tool, LoB has its origin in the manufacturing industry where it has been successfully used for a long time to plan and control repetitive one-off projects (Heinrich et al., 2005). The resource oriented LoB technique has also been developed for the construction industry, but has often been disregarded in favor for the activity oriented Critical Path Method (CPM) developed as an extension of the Gantt/bar chart (Heinrich et al., 2005). Only recently, with the development of LoB for commercial use in Finland (e.g. Soini et al., 2004), has the technique been reborn and is now considered, by some academics, as the

future in construction planning and management (Kenley, 2005). In practice, LoB has mainly been used for projects with a large degree of repetition over a relatively small number of discrete activities (Heinrich et al., 2005). However, LoB has also been successfully used on large scale projects in Finland (Soini et al., 2004).

LoB is a specific type of linear scheduling method that allows the balancing of operations such that each activity is seen as being continuously performed, even though the work is carried out in various locations (Heinrich et al., 2005). Scheduling with LoB is oriented towards the required delivery of completed units and is based on knowledge of how many units must be completed on any day so that the programmed delivery of units can be achieved (Arditi et al., 2002). LoB considers location explicitly as a dimension which allows for easier planning of continuous resource use, which in turn enables cost savings, cuts in project duration, reduced work flow variability, and less schedule risks as subcontractors crews can be kept on site until their work is finished (Soini et al., 2004).

Scheduling a project with LoB begins by breaking down the project in physical sections (i.e. locations), such as for example 'location 1' included in 'building A', which is part of 'project X'. Creating tasks in the schedule (i.e. lines) is done by using items from the bill of materials or cost estimation in a project. For example, from the bill of quantity item 'floor elements' the following tasks are derived: assembly of floor element, finish ceiling and finish flooring. In this way a specification is made for the amount of work per location in a project for a construction crew. Based on these quantities and task description, the required crew size can be determined. The bill of quantity items and cost estimation define what should be done and the tasks in the LoB schedule define how this is done. This relation is often not explicitly made in CPM schedules and when done so it leads to very detailed and unmanageable schedules (Huber and Reiser, 2003).

Figure 1 shows the most common deviation types that can be identified by using LoB diagrams (Jongeling and Olofsson, 2006). These deviation types indicate scheduling mistakes and opportunities to plan for a stable and continuous flow of work through locations of a project. The two main principles used to minimize the deviations and to plan for continuous work flow with LoB diagrams are synchronization and pacing. Synchronization concerns the effort to achieve a similar production rate for all activities. A synchronized schedule can be identified by parallel lines (i.e. parallel tasks) that show a constant time-space buffer between different tasks. Pacing means

that the activities are scheduled to continue from one location to another without interruptions.

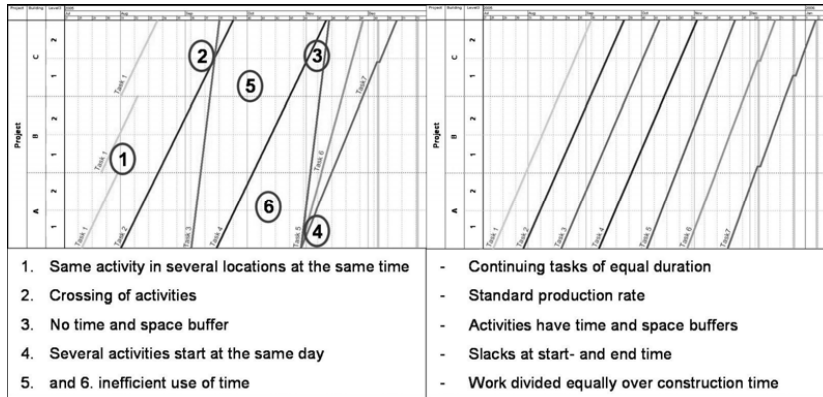

Figure 1 Left: Line-of-Balance diagrams showing common deviation types. Right: Typical solutions to these deviations. Locations are represented on the Y-axis and project time on the X-axis (Jongeling and Olofsson, 2006).

The LoB technique entails useful mechanisms for the planning of work flow. However, the LoB technique does not explicitly address the spatial configuration of activities. In order to identify what part of a building is related to an activity, users have to use 2D drawings to understand the spatial implications of an activity. Combining LoB with 4D CAD could add spatial insight in construction planning that could improve the quality of the process design.

2.2 Simulation and visualization using 4D CAD workspace models

4D CAD models allow project participants to simulate and analyze what-if scenarios before commencing work execution on site (McKinney, 1998). Common for projects using 4D CAD is visualization of design decisions and improved communication of these decisions in the design phase (Woksepp et al., 2005). Based on Japanese experiences, Nakagawa (2005) illustrates the importance of visualization for the maintenance of a synchronized and paced work flow and for the implementation of Lean Thinking in construction. Construction site workers tend to focus on their own tasks and therefore become indifferent to other related activities which often create waste in the

form of rework and errors, particularly in projects with a large number of activities and crews. Proper visualization of overall project progress is encouraging workers to improve their own work and the coordination with other work crews, which facilitates work flow while waste is reduced. Continuous improvement through learning is a fundamental characteristic of Lean Thinking (Womack and Jones, 2003).

4D CAD models are typically created by linking building components from 3D CAD models with activities that follow from CPM schedules (e.g. Koo and Fischer, 2000; Tanyer and Aouad, 2005). Building components that are related to activities that are ongoing are highlighted. The 4D CAD model provides the user with a clear and direct picture of the schedule intent and helps to quickly and clearly communicate this schedule to different stakeholders in a project. 4D CAD models provide planners with a spatial insight in the scheduling process of construction operations which is not provided by using 2D drawings in combination with CPM schedules or LoB diagrams.

The difficulty of applying flow-based thinking in today's 4D CAD models arises from the fact that these models are based around discrete activities from CPM schedules. In addition, 3D CAD building models, also referred to as Building Information Models (BIM) (Autodesk 2003), on which today's 4D CAD models are based, do not represent the locations of crews and other resources. As a result, the application of 4D CAD models to model and analyze work flow is limited (Akbas, 2004). Additional 3D components, such as 3D spaces, are needed that can visualize the flow of resources through a project. An advantage of using 3D workspace models is that ongoing activities inside a building can be easily analyzed in contrast to traditional 4D models that are based on 3D CAD building components. In the next section we illustrate how the LoB technique can be used in combination with a 3D space model as an alternative to CPM scheduling for 4D modeling to plan and manage construction operations from a work flow perspective.

3. Application in practice

The empirical part of this paper involves planning and simulation of the construction process of a multi-storey timber housing project using LoB and 4D CAD. Data is collected from a case study of the construction of 95 apartments in five six-storey buildings with basic floor plan according to

Figure 2. Floor and wall elements are to a high degree prefabricated and include a load-carrying system, sub-ceiling, installations and covering.



Figure 2 Left: the multi-storey timber housing project (picture by Svante Harström). Right: the basic floor plan of all houses.

We applied the LoB scheduling and 4D CAD method to one of the buildings in the multi-storey timber housing project according to the method shown in Figure 3. First, the LoB diagram was developed from the original master planning of the project. Then, the 4D CAD model was created, based on schedule data and the hierarchical logic of locations. Finally we conducted a comparative analysis of the LoB diagram and the 4D CAD model.

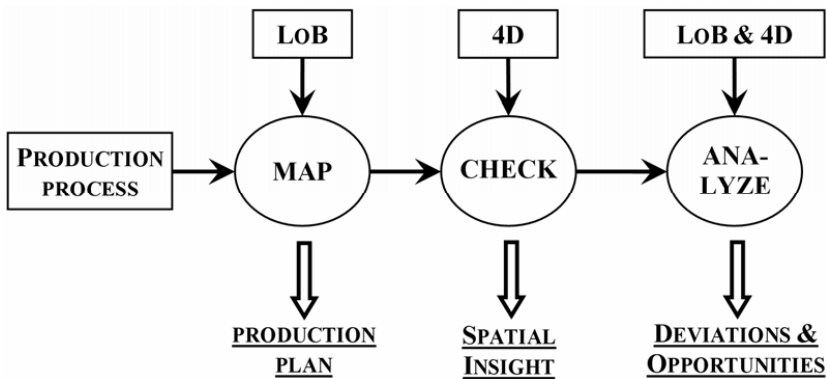

Figure 3 Scheduling and analysis of work flow using LoB and 4D CAD.

The original production plan for the project was performed using Gantt scheduling with a low level of detailing, i.e. production tasks were only

scheduled in time with no spatial consideration except for the occasional division of tasks between floors. The original schedule was clearly constructed with a solve-it-on-site mentality which became apparent from observations of actual work performed on the construction site (Björnfot and Stehn, 2005). In our study the original Gantt bar charts was used as input for the LoB diagrams to better understand the flow of resources through locations in the case study project.

The structural design of the buildings was performed using 2D CAD by which all structural elements, installations and interior accessories were detailed. The drawings, over 100 in total, complicated the communication of the design intent and production schedule. Project participants had difficulties in relating the different 2D drawings to one common view of the project. The level of detail of the installation design was also not sufficient to produce accurate shop floor drawings. We used the available 2D CAD files as a basis to generate a 3D space model of the case study project that we subsequently used as input for the 4D model. The spatial hierarchy of the 3D space model and of the LoB diagram is identical.

3.1 Preparing the Line-of-Balance diagram and 4D model

Scheduling using LoB requires a relevant spatial division of the project. This division should be based on the logic of the work being performed. The spatial logic could not be derived from the available Gantt schedules alone due to the low level of detail. Therefore, the spatial division from the original schedules was supported by field studies on the construction site.

The construction process for the five buildings of the case study project was performed in two stages; assembly of load-bearing structure, and structural and internal finishing work. In the first stage the load-bearing structure was assembled using prefabricated wall and floor elements, Figure 4. This work was performed in a nine day assembly cycle for each floor, beginning with '*wall linings*', assembly of '*outer walls*' and '*inner walls*', and ending with the assembly of '*floor elements*'. The variability in assembly time was large, ranging from about ten minutes up to an hour per element. This was mainly caused by incorrect element dimensions and tolerances due to errors in the design and manufacturing process. These errors resulted in rework on site, e.g. a complete waste of resources. Even though the assembly of the '*floor elements*' for each floor was generally performed over a two day cycle, a three day span was given to account for the great variance in assembly time. Despite the problems with element tolerances, the assembly of the load-bearing

structure was generally considered to be productive and efficient by all participants involved in site production.



Figure 4 Assembly of floor and wall element on the construction site.

The second stage of the construction process comprised of finishing work. The finishing of the structure included activities such as *'adjust ceiling'*, *'sprinklers piping'* and *'HVAC installation'*, while internal finishing work denoted activities such as *'painting'*, *'electricity finishing'* and *'plasterboard walls'*. The production at this stage was problematic in which numerous design and planning errors became apparent (Björnfot and Stehn, 2005). Even though a high degree of prefabrication was used for the floor and wall elements (e.g. floor elements included installations) a large amount of finishing work was required to complete the elements and finish the building interior. No detailed planning was available for the interior work, due to the fact that these activities were mostly managed ad-hoc on site.

3.2 Production activities and spatial hierarchy

From site observations during production it was found that the spatial work flow for assembly of the load-bearing structure and interior works progressed from apartment to apartment. Based on these observations we divided a building storey into four types of spaces; three apartment spaces of approximately equal size and a common space for staircase and elevator shaft that was slightly smaller, Figure 5. This spatial hierarchy is used in the LoB diagram and 4D CAD model. In addition, 3D workspaces were included to represent activities related to kitchens, bathrooms and service shafts.

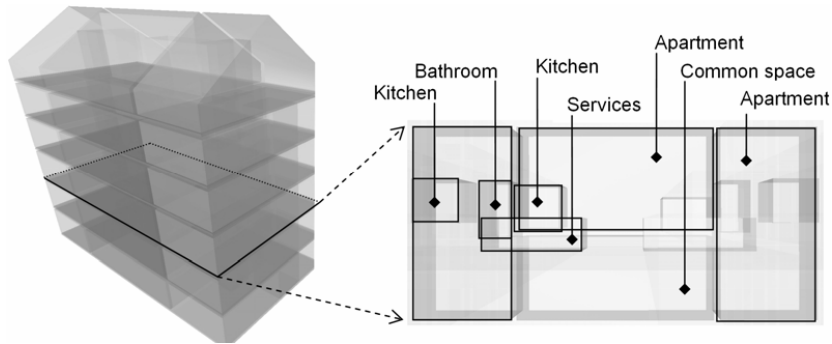

Figure 5 Left: 3D model of the building containing space objects used for 4D simulations. Right: 3D space model of one building storey. Apartments contain spaces for kitchens, services and bathrooms. Spaces for services overlap with spaces for kitchens and bathrooms.

4. Case study results

4.1 Analysis of the LoB diagram

The LoB schedule (Figure 6) is based on the spatial hierarchy in Figure 5 and created with Graphisoft Control (Graphisoft, 2006). A quick look at the LoB schedule verifies the main view from production personnel about the construction process: assembly of the load-bearing structure was efficient while structural and internal finishing work was troublesome. According to the LoB schedule, the assembly process of the load-bearing structure appears to be reasonably synchronized and paced. In practice, assembly progressed according to the master schedule even though occasional rework had to be performed due to deficient elements. No major delays resulted from the rework since one extra day, serving as a time buffer, was scheduled in assembly of the load-bearing structure.

Execution of structural and internal finishing work was troublesome. Most of these problems were related to the planning of work, where assignments performed by crews from the main contractor and subcontractors were planned daily due to the low level of detail in the construction schedule. Anecdotal evidence from interviews with the workers on site suggests that construction crews were everywhere and it was hard to keep control of what construction tasks were performed, by whom, where and why (Björnfort and Stehn, 2005).

Some of this confusion is evident from the LoB schedule where the common planning deviations depicted in Figure 1 were apparent in the case study (highlighted in Figure 6), e.g. crossing of activities, lack of buffers, and activities starting on same day. Deviation type 1, same trade at several locations at the same time, could not be detected in the LoB diagram even though it was apparent from site observations that multiple trades had work-in-process in several locations at once, hindering subsequent trades from performing their work on schedule. With the identified deviations from the LoB diagram in mind, we simulated the construction process using the 4D CAD workspace model to provide additional spatial insights in the construction process.

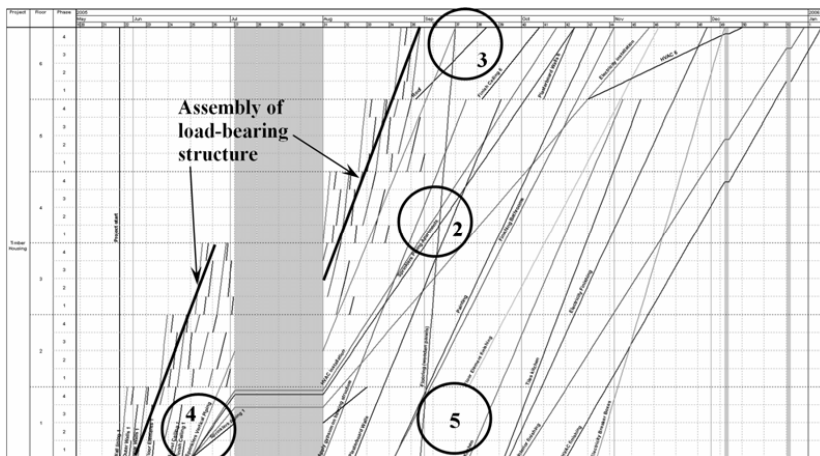

Figure 6 LoB schedule of the work performed during production. Circles depict possible schedule problems according to the deviations identified in Figure 1.

4.2 Analysis of the 4D workspace model

Activities from the LoB diagram were imported to a 4D simulator (Ceco 2006) in which the 3D space model of the case study project was linked to the schedule data. Different colors were used to distinguish different types of activities and different (sub)contractors. After the linking process was completed the 4D model was simulated and the identified deviations from the LoB diagram (Figure 6) was analyzed, Table 1. In the 4D model, congested work spaces are indicated with a dark grey conflict color.



IDENTIFIED DEVIATION	4D SNAPSHOT	BRIEF ANALYSIS
		<p>Two activities are planned at the same time in the same space, indicated by the crossing activities in the LoB diagram and the congested workspace (red) in the 4D model. Synchronization of these activities will improve the work flow through the location.</p>
		<p>The LoB diagram shows a conflict on floor 6, but the 4D model indicates that the sprinkler activity is limited to a specific zone, which only partially overlaps work on the roof. Therefore, this conflict does not necessarily have to lead to congestion problems on site.</p>
		<p>Several activities start on the same day shown in the 4D model as a conflict (red) on floor 1. The 4D model shows that some of the tasks could start in other spaces on floor 1. This type of congestion can be predicted and avoided using the 4D model and LoB diagram, thereby avoiding unnecessary site management.</p>
		<p>The LoB diagram and the 4D model show inefficient use of available workspace on floor 1. At the same time the workspaces on floors 4 and 6 are congested (red). Using the 4D model, a schedule opportunity can be identified allowing for a later start of the subsequent activity, which avoids the identified congestion on floor 4 and 6.</p>

Table 1 Analysis of deviation types using 4D simulation of the LoB diagram.

The use of a 4D model in addition to the LoB diagram was, in this case, found to be mostly useful for communication and visualization of the LoB diagram. Most of the deviations could be identified with the LoB diagram alone.

However, the spatial context of a number of deviations as identified in the LoB diagram became clearer in the 4D model, compared with representation in the LoB diagram. For example, the space conflict on floor six (deviation type 3 in Figure 6 and Table 1) appeared to concern a partial overlap of work spaces from installation of sprinklers and the roof finishing, which was considered acceptable after viewing the 4D model. Also the flooring activity on floor six could be rerouted later to allow for work on sprinklers and the roof. In addition, the 4D model proved to be of complementary use to the LoB diagram in the process of identifying available work space for congested activities on floors four and six (deviation type 5 in Figure 6 and Table 1). The 4D model also provides a clearer overview of available workspaces compared to the LoB diagram.

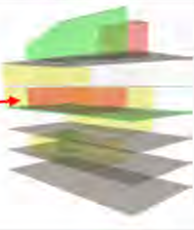
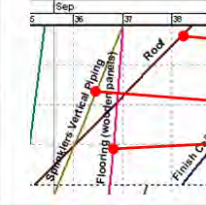
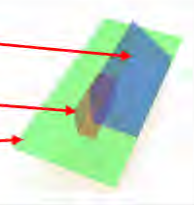
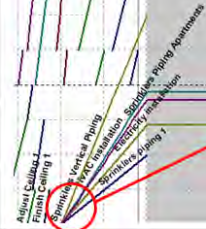
Partial overlap of workspaces (deviation type 3 in Figure 6 and Table 1) is a situation that is difficult to manage with the LoB technique. One solution is to use a more detailed spatial division in the definition of LoB location hierarchy. However, this will complicate the planning and management of the LoB schedule. The LoB is based on a well defined spatial sub system, such as a floor consisting of apartments, divided into rooms. This type of static spatial hierarchy of workspaces is not present during all stages of the construction process. The distribution of and boundaries between workspaces is generally much more complex and less clear. Installations of sprinklers are, for example, centered on vertical shafts in the building and do not follow the apartment-based distribution of work spaces. Here, 4D CAD models can be used as a complement to the LoB diagram to provide additional information of spatial irregularities and overlaps in planning and management of construction work tasks.

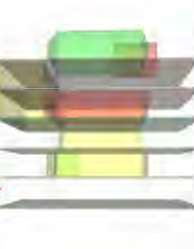
5. Discussion and conclusions

In this paper the LoB scheduling technique and 4D CAD was applied to a case study of a multi-storey timber housing project. The main strength of the LoB scheduling technique is the possibility of obtaining a synchronized and paced planning of operations, which creates opportunities for construction work to flow unhindered from work space to work space. 4D CAD visualizes the work to be performed, identifying possible space congestions and allowing for more detailed evaluation of different production plans, work methods and design decisions. The main strength of the integrated use of LoB and 4D CAD is the straight-forward evaluation of the feasibility of the production schedule in

which users are provided with a powerful set of tools to schedule, manage and communicate project plans. The application of scheduling techniques for work flow was limited to the planning of construction crews through the case study project. For a more comprehensive work flow analysis, we suggest that additional resources that can affect the flow of work are taken into considerations, such as materials, temporary structures and equipment.

By creating a relatively simple LoB schedule (Figure 6) and performing a quick analysis, it was shown that many potential problems quickly become evident, e.g. possible work space congestion and lack of time buffering. The 4D model provided additional insight in the spatial context of scheduled construction activities. In this paper a 4D workspace model was used to visualize the flow of work during production. 4D models based on spaces are suitable for work flow analyses, but component-based 4D models are required to facilitate for example constructability analysis and supply chain management. A 4D workspace model can in this respect be considered a supplement to the common component-based 4D model. To further improve the feasibility of schedules and to better control the production process, the Last Planner system and specifically the metric Percent Plan Completed (PPC) (Ballard, 2000) can be integrated so that planning can be continuously improved upon through feedback from work execution on site.

Application and integration of LoB and 4D CAD workspace simulations can support the set-up of a balanced and steady work flow in the construction process. The possibility of using the tools for evaluation of schedule feasibility through the visualization of work flow can aid construction in securing constructability. Additionally, the possibility of identifying potential waste and to plan for uninterrupted work flow through LoB and 4D CAD supports the main principles of Lean Thinking (Womack and Jones, 2003); pacing of work at stable productivity levels without interruption promotes quality and learning through continuous improvements, potentially reducing future waste generation (Arditi et al., 2001). Based on the insights provided in this paper, LoB and 4D CAD can be considered two important tools for the increase of efficiency and productivity in the construction industry. We believe that virtual design and construction methods based on principles from lean construction can contribute significantly to the value of the product and the elimination of waste in any construction project. Therefore, more studies are recommended where both areas of research can be combined in the design and construction of building facilities, such as methods for lean design and lean supply chain management.

References

- Akbas, R. 2004: Geometry-based modeling and simulation of construction processes. Department of Civil and Environmental Engineering, Stanford University.
- Arditi, D., Tokdemir, O. and Suh, K. 2001: Effect of learning on line-of-balance scheduling. *International Journal of Project Management* 19: 265-277.
- Arditi, D., Tokdemir, O. and Suh, K. 2002: Challenges in line-of-balance scheduling. *Journal of Construction Engineering and Management* 128 (6): 545-556.
- Autodesk 2003: White Paper: Building Information Modeling in Practice, www.autodesk.com/buildinginformation
- Ballard, G. 2000: The last planner system of production control. School of Civil Engineering, Faculty of Engineering, University of Birmingham.
- Björnfort, A. and Stehn, L. 2005: Product design for improved material flow – a multi-storey timber housing project. Proceedings of the 13th Annual Conference of the Int. Group for Lean Construction, Sydney, 19-21 July 2005, pp. 297-306.
- Bertelsen, S. and Koskela, L. 2005: Approaches to managing complexity in project production. Proceedings of the 13th Annual Conference of the Int. Group for Lean Construction, Sydney, 19-21 July 2005, pp. 65-71.
- Ceco 2006: Ceco4D – Model Publisher & 4D Viewer, www.ceco.se
- Graphisoft 2006: Graphisoft Control, www.graphisoft.com
- Heinrich, G., Tilley, P. and Koskela, L. 2005: Context of production control in construction. Proceedings of the 13th Annual Conference of the Int. Group for Lean Construction, Sydney, 19-21 July 2005, pp. 189-198.

- Huber, B. and Reiser, P. 2003: The marriage of CPM and Lean Construction. Proceedings of the 11th Annual Conference of the Int. Group for Lean Construction, Blacksburg, 22-24 July 2003.
- Jongeling, R., Kim, J., Mourgues, C., Fischer, M. and Olofsson, T. 2005: Quantitative analysis using 4D Models – an explorative study. Proceedings of the First International Conference on Construction Engineering and Management, Seoul, 16-19 October 2005, pp. 830-835
- Jongeling, R., and Olofsson, O. 2006: A method for planning of work-flow by combined use of location-based scheduling and 4D CAD. Automation in Construction (article in press)
- Josephson, P-E. and Saukkoriipi, L. 2005: Waste in construction projects – the need of a changed view (in Swedish). Fou-väst, report 0507.
- Kenley, R. 2004: Project micromanagement: practical site planning and management of work flow. Proceedings of the 12th Annual Conference of the Int. Group for Lean Construction, Elsinore, 3-5 August 2004.
- Koo, B. and Fischer, M. 2000: Feasibility study of 4D CAD in commercial construction. Journal of Construction Engineering and Management 126 (4): 251-260.
- McKinney, K. and Fischer, M. 1998: Generating, evaluating and visualizing construction with 4D-CAD. Automation in Construction 7 (6): 433-447
- Nakagawa, Y. 2005: Importance of standard operating procedure and visualization to implement lean construction. Proceedings of the 13th Annual Conference of the Int. Group for Lean Construction, Sydney, 19-21 July 2005, pp. 207-215.
- Soini, M., Leskelä, I. and Seppänen, O. 2004: Implementation of line-of-balance based scheduling and control system in a large construction company. Proceedings of the 12th Annual Conference of the Int. Group for Lean Construction, Elsinore, 3-5 August 2004.
- Tanyer, A. and Aouad, G. 2005: Moving beyond the fourth dimension with an IFC-based single project database. Automation in Construction 14 (1): 15-32.

Tommelein, I., Riley, D. and Howell, G. 1999: Parade game: impact of work flow variability on trade performance. *Journal of Construction Engineering and Management* 125 (5): 304-310.

Woksepp, S., Jongeling, R. and Olofsson, T. 2005: Applying Virtual Reality and 4D CAD models in the scheduling process of a large pelletizing plant. *Proceedings of CONVR – Conference on Construction Applications of Virtual Reality*, Durham, 12-13 September 2005.

Womack, J. and Jones, D. 2003: *Lean thinking: banish waste and create wealth in your corporation*. London: Simon & Schuster UK Ltd.

MACRO- AND MICRO-MANAGEMENT OF WORK FLOW USING LOCATION-BASED SCHEDULING AND 4D CAD

Authors

Rogier Jongeling^a, Thomas Olofsson^a

Affiliation

^a eBygg Center, Civil and Environmental Engineering, Luleå University of Technology, Luleå, Sweden

Submitted to Computer-Aided Civil and Infrastructure Engineering - CACAIE
(March 2006)

Abstract

Current scheduling techniques do not provide adequate support for the planning and management of construction tasks due to practical and methodological reasons. This article presents a novel process method for planning and control of work flow where location-based scheduling is used in combination with 4D CAD models. Two levels of work flow management are introduced, macro- and micro-management. Scheduling of work flow on macro-level is suggested as an alternative to the common discipline-oriented work breakdown scheduling approach. Macro-level scheduling is suggested to be initiated in the design- and production planning process using 3D CAD models from which a bill of quantities can be extracted, structured according to a location-based logic. The micro-management of work flow is intended to be an instrument in the planning and control of day-to-day construction tasks. Based on the macro-management work flow plan, more detailed look-a-head schedules can be constructed where necessary prerequisites for efficient and safe execution of construction tasks can be considered. The two levels of the work flow management process are exemplified in an industry case study project.

Keywords

4D CAD, location-based scheduling, construction planning, work flow

1. Introduction

Inspired by production concepts from the manufacturing industry, the construction industry is in the process of adopting new management philosophies to face the challenges posed by increasingly demanding projects. The design and construction period of construction projects intensifies because projects are getting larger, the time to complete is getting shorter, and client requirements are increasingly complex and can vary greatly from one project to another (Fischer 2004). The intensity of work and the severe pressure on time and cost require predictable and reliable performance of participating organizations in projects. During the construction process this requires a continuous and reliable flow of resources through locations on a construction site, termed work flow. Current practice and methods of managing construction projects fail to consistently deliver and maintain a continuous and reliable work flow. An in-depth study of seven Swedish construction projects reveals that a construction worker spends only 15-20 % of the time on direct work (Josephson 2005). Approximately 45 % is spent on indirect work (preparations, instructions, getting material, etc.). The remaining 35 % is spent on redoing errors, waiting, disruptions, etc., i.e. a waste of time. We believe that improved planning and control methods can contribute significantly to an efficient flow of resources and reduction of waste in the construction process.

In this article we suggest a planning and control method that combines existing and novel techniques for process design and -control. The purpose of the article is to provide a practical method that can facilitate the management of work flow in construction. Currently, planning and management of work flow is often not considered as a result of today's scheduling practice and methodological difficulties (Jongeling 2006).

Project planning and control is typically structured according to a Work Breakdown Schema (WBS). Using this schema, planners decompose a project into activities that they associate with one or more building components that make up the project. Each activity is included in a network of activities often presented in a bar chart that describe the proposed schedule of a project. The customary approach is to prepare a master schedule that is used as a basis for plans of more specific nature, like more detailed short-term plans (Koskela 1999). These schedules are in many cases discipline oriented and do not explicitly consider the spatial layout of a project nor the spatial interaction between construction trades. Typical problems that arise as a result of this planning practice are suboptimization, out-of-sequence work and inefficient work- and space buffers. Updating of the master schedule is usually deficient,

and consequently task management, at the short term, is largely done informally by the foremen or left to the teams on site to be taken care of by mutual adjustment (Koskela 1999). As a result, macro-management of work flow, which involves the management of the flow of resources through locations in projects, is left to ad hoc management on site where there is little opportunity to change construction execution strategies (Jongeling 2005).

A fundamental part of work flow management concerns planning and control of construction tasks on a day-to-day basis (Hopp 1996). A construction task is usually an assembly operation that is carried out in a certain location in a certain time frame. Planning and controlling a construction task also requires the management of a number of preconditions that need to be satisfied for the execution of a specific task, here defined as micro-management, Figure 1.

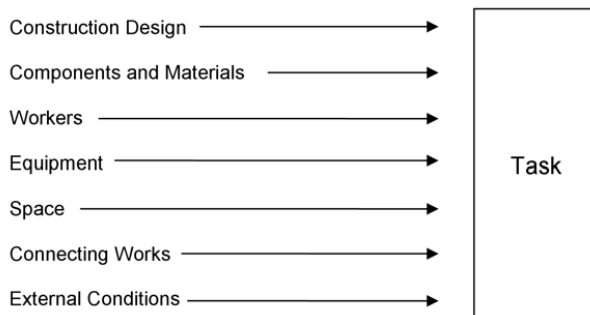

Figure 1: The preconditions for a construction task (Koskela 1999)

There are at least seven resource flows (i.e. preconditions) that unite to generate the task result, each of which has to be planned and controlled (Koskela 1999). Planning these preconditions so that the work on site is not interrupted is an inherently difficult task. Using the CPM method for this purpose leads to very detailed schedules that are difficult to use and to communicate (Huber 2003). Methods and systems are starting to become available for the micro-management of construction tasks of which the Last Planner method currently is the most common technique (Ballard 2003). The method is based on the principle that tasks should be sound regarding their prerequisites, also referred to as the Complete Kit (Ronen 1992). Kenley (2004) argues that Last Planner is a typical example of a method for management of construction tasks that is derived from and limited to the application of an activity-based scheduling technique, such as the CPM

method. Activity-based methods are based around discrete activities that limit the identification of work flow. An alternative to activity-based scheduling for macro- and micro-management of construction tasks is location-based scheduling. The flow of resources through locations and the resultant ability to control the hand-over between these locations greatly empowers the management of construction from the perspective of day-to-day management of activities (Kenley 2004).

This article concentrates on the management of work flow based on location-based scheduling. The article suggests that the spatial configuration of projects requires a 4D modeling approach (i.e. time-space approach) to management of construction tasks. The key characteristics of 4D modeling and location-based scheduling techniques are first discussed. Then, a proposed process method for the management of work flow, based on the application of 4D models on a macro- and micro-level, is presented.

2. 4D modeling

The spatial configuration of work locations in construction projects is an important factor for the planning of work flow (Akbas 2004). Commonly used CPM schedules do not provide enough information pertaining the spatial context and complexities of project components (Koo 2000). In order to identify what building components are related to a specific work task, construction crews have to use 2D drawings to understand the spatial implications of an activity. Different actors may develop inconsistent interpretations of the relations between activities in a schedule and project components. This practice is prone to errors and limits the understanding of the spatial context of work flow management in projects.

4D modeling is a process method in which schedule data and spatial data are combined. The method visualizes 3D CAD models in a 4-dimensional environment (i.e. time-space environment), facilitating analyses of different production strategies before work on site is initiated (McKinney 1998). 4D models are typically created by linking building components from 3D CAD models with activities from activity-based scheduling methods. Building components that are related to an ongoing activity are highlighted, providing users with a spatial insight of the construction process. 4D models are currently mainly used to communicate a master schedule to different stakeholders in a project.

Macro-management of work flow with 4D models requires a hierarchical decomposition of 4D models into locations in order to plan the flow of resources through these locations. Today's 4D models are not structured according to such logic, thereby limiting the use for macro-management. Micro-management of construction tasks requires detailed 4D models. These types of 4D models are currently difficult to maintain and update due to practical and methodological reasons (Jongeling 2006). 4D models are often based on CPM schedules that are time-consuming to manipulate when the level of detail and complexity of projects increases. In addition, the 3D CAD models on which most of today's 4D models are based, are limited to building components. Micro-management of construction tasks involves planning and control of aspects that are not directly related to building components. For example, installing plasterboard walls requires, among other things, work space for crews and a place for material storage. These aspects affect the flow of work on construction sites, but are not included in today's building component-based 4D models.

4D models provide project participants with a spatial insight in the scheduling process of construction operations. Management of work flow on a macro- and micro-level is limited and requires a different approach to creating and managing 4D models. In the next section we study location-based scheduling as a potential planning and control method according to which 4D models could be structured.

3. Location-based scheduling

Location-based scheduling techniques use lines in diagrams to represent different types of activities performed by various construction crews that work on specific locations in a project. Variations of the method include 'Line-of-Balance', 'Flowline', 'Vertical Production Method', 'Time-Location Matrix model' and 'Disturbance Scheduling' (Akbas 2004; Kankainen 2003; Kenley 2004; O'Brien 1975; Stradal 1982). In this article we focus on the Line-of-Balance method, which is increasingly applied in practice (Seppänen 2004). The Line-of-Balance technique is not new, but practical use has been limited due the strong tradition of activity-based planning methods and the absence of software packages that support location-based planning.

Macro-management of work flow with the Line-of-Balance method begins by breaking down the project in physical sections (i.e. locations), such as for

example ‘floor 2’ included in ‘building C’, which is part of ‘project X’. Construction tasks are derived from a bill of quantities with location data (Kankainen 2003). Based on the quantities per location and specified activities, the required crew size can be determined. Control emerges through the hand-over of locations from one work package to another as well as the hand-over from one location to another of the work crew. Emphasis is placed on minimizing the risk for disturbance by managing time- and space buffers between work crews.

The most common deviation types that can be identified by using Line-of-Balance diagrams are included in Figure 2. These deviation types represent scheduling mistakes and opportunities to plan for a reliable and continuous flow of work through project locations (Seppänen 2004). Two main principles are used to minimize these deviations: synchronization and pacing. Synchronization concerns the effort to achieve a similar production rate for all activities. A synchronized schedule can be identified by parallel lines that show a constant time-space buffer between different tasks, Figure 2. Pacing means that the activities are scheduled to continue from one location to another without interruptions.

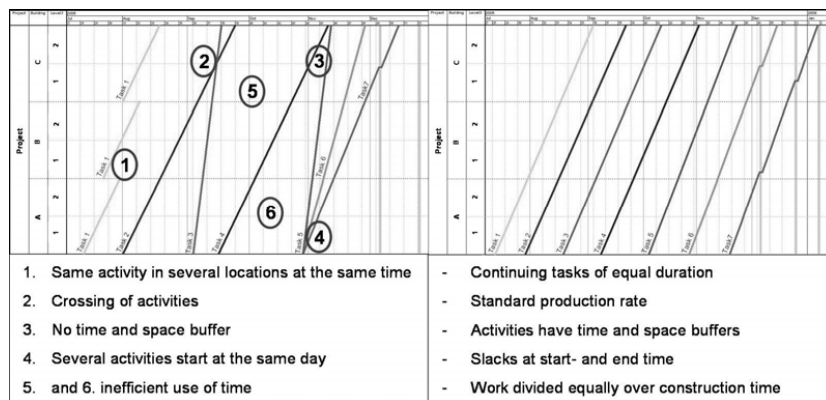

Figure 2: (Left) Line-of-Balance diagrams showing common deviation types. (Right) Typical solutions to these deviations. Locations are represented on the Y-axis and project time on the X-axis (Jongeling 2006)

Macro-management requires a continuous effort to identify and address deviations in the schedule. Compared to activity-based scheduling methods, the

Line-of-Balance scheduling and control technique appears to entail useful mechanisms to manage work flow on construction sites.

The application of the Line-of-Balance scheduling method for micro-management concerns the planning and control of preconditions for construction tasks. Practical use of the method for this purpose is limited to date and is still a research issue. A key function for this level of scheduling is the provision of information needed to ensure work flow, work reliability, avoidance of interference, improved quality and reduced rework (Kenley 2004). Planning and controlling all of the preconditions for sound execution of construction tasks appears to push the limits of the Line-of-Balance scheduling technique. There are a number of issues that need to be addressed in order to use the Line-of-Balance method for micro-management of construction tasks. Line-of-Balance schedules currently concentrate on the scheduling of crew locations and do not specify the types of space that a location includes or how the use of one location results in space requirements for another location. The space usage on construction sites can be classified into different types of spaces. Akinci et al. (Akinci 2002) identify the following different types of spaces: building component space, material space, labor space, equipment space, space for temporary structures and hazardous space. An activity on a floor might for example create a hazardous situation for the execution of construction work in a location on a floor beneath. It is currently unclear how the Line-of-Balance scheduling method can be applied for the management of different types of spaces, which we consider part of micro-management of work-flow.

Management of spaces is especially demanding in projects with complex spatial configurations. Defining locations in these types of projects for crews, material, equipment and temporary structures, requires a 4-dimensional distribution of locations. Some of the spatial distributions of locations are too complex to represent in a symbolic 2-dimensional tree of locations. Different trades work according to different spatial distributions and these distributions can change as the project progresses. The spatial hierarchy of today's Line-of-Balance diagrams is often based on the spatial distribution of the final product, but this distribution might not be applicable for all types of construction work. Different types of work might need different distributions of locations.

The Line-of-Balance scheduling method requires further development to facilitate practical application of the method for micro-management. An important component of this micro-management is communicating the schedule of a project beyond the project manager to the site personnel, thereby

addressing one of the major flaws with project scheduling: the failure of site personnel to understand, implement and manage a project schedule (Kenley 2004). Micro-management of construction tasks leads to detailed Line-of-Balance diagrams of which the spatial context of tasks' preconditions can be difficult to communicate with site personnel, thereby not solving the aforementioned flaw of task management on construction sites.

In summary: the Line-of-Balance scheduling technique appears to entail useful mechanisms for the management of work flow on a macro-level in construction projects. However, micro-management with Line-of-Balance diagrams appears to be more challenging as a result of the spatial configuration of construction tasks' prerequisites. Combining the Line-of-Balance scheduling technique with 4D modeling could add spatial insight in the planning of work flow that in its turn could add to the quality of the process design. In the next section we propose a process method for a combination of both methods.

4. Proposed method

We propose the following method for macro- and micro-management of work flow in which we focus on process design by applying the Line-of-Balance method and 4D CAD.

4.1 Macro-management

The first step concerns the definition of locations by a project planner, estimator and 3D modeler. The definition of locations is an important step in the planning process as it defines the data structure for subsequent processes that are part of the overall planning process. The subdivisions should follow the spatial subdivisions that can be identified in a project. Locations can be hierarchically structured, but only where there is a physical reality (Kenley 2004). The structure should be logical and the boundaries of the locations should represent physical boundaries.

The second step involves preparation of 3D CAD models according the defined project locations. Each 3D object is mapped to a project location by a 3D modeler. If needed, additional locations can be defined by the 3D modeler in consultation with the project planner and estimator (Fischer 2004). The 3D modeling process also includes the modeling of 3D space objects that represent the defined project locations.

The third step is the cost estimation process. Inputs for this process are 3D CAD models from which a location-based bill of quantities is made. The cost estimation is made by defining recipes for building components. Each recipe includes methods (i.e. a number of tasks) and resources (e.g. man hours) needed for the installation of a building component. The output of the cost estimation process is location-based 3D CAD data with recipes specified for each 3D CAD object. This data is the input for the fourth process, which is the planning process with the Line-of-Balance technique.

The fourth step involves the definition of tasks in the Line-of-Balance diagram by using the methods that are defined in the 3D CAD models during the cost estimation process. Defined tasks can be grouped into task groups, to allow for different abstraction levels of the Line-of-Balance diagram. For example, all tasks related to a concrete building structure can be grouped and all tasks related to interior finishing can be grouped. For each of the construction tasks, planners define a duration and required resources. The Line-of-Balance diagram is structured according to the exact same location hierarchy as the 3D CAD model and cost estimation. By synchronizing and pacing the construction tasks, planners can plan and control the flow of resources through locations in a project.

The fifth step concerns modeling and simulation with 4D CAD. The 4D modeling process includes linking tasks from the Line-of-Balance schedule to building objects and spaces from the 3D CAD models. We define this type of 4D models as 4D macro-models. The 4D modeling process results in 4D simulations that can be analyzed, and that can possibly result in suggestions for improvements for the 3D CAD models or Line-of-Balance diagram.

4.2 Micro-management

The described process so far concerns the macro-management level of work flow management. The next step in the planning process concerns micro-management of construction tasks. Micro-management is based on five principles of the Last Planner method (Ballard 1998):

1. A look-ahead planning with a time horizon of three weeks is made. This short-term planning works as a pull system for the planning and management of prerequisites for scheduled construction tasks
2. Construction tasks should be sound regarding their prerequisites
3. A buffer of tasks is maintained for each crew enabling a crew to switch to another task when an assigned task cannot be carried out.

4. Realization of assignments is measured and monitored
5. Causes for non-realization are investigated and removed

Based on these principles, we suggest establishing 4D models that include construction task prerequisites and that are created with a time horizon of three weeks. We define these types of models as 4D micro-models. The first step in this micro-management process involves the isolation of tasks that are scheduled for the coming three weeks. This is done by using the Line-of-Balance schedule and the 4D macro-model. Construction tasks are identified and listed for every construction day of the look-ahead planning. At this stage the 4D micro-model is created in which building components are selected and linked for scheduled construction tasks. The 4D micro-model can be based on the 4D macro-model that is further refined. The use of 4D micro-models can be focused on areas that are considered critical to the overall flow of work.

The second step involves the planning of construction task prerequisites by further refining the 4D micro-model. Planners allocate spaces in the 4D micro-model for every prerequisite with a spatial property, such as crews, equipment, temporary structures, etc. In addition to planning spaces for task prerequisites, spaces should be planned according to identified space types by Akinci (2002). Allocating spaces for different types of space-usage by using a 4D model is an important step in evaluating the feasibility for productive and safe execution of construction tasks. Planning and managing the different space types requires additional 3D space objects that should be added by the 3D modeler, together with the project planner.

The third step in the micro-management process involves analyses of the 4D micro-model. The 4D modeling process results 4D simulations and 4D content. 4D content is defined as quantitative data extracted from 4D models to support 4D-based-analysis of construction planning information (Jongeling 2005). Analyses of the 4D micro-model can result in suggestions for changes in the planning for preconditions of construction tasks.

This is an iterative process in which the processes in the macro-planning process are repeated until a construction schedule emerges that ensures a continuous and reliable flow of resources through different location in a project. The different steps of the micro-management process are continuously repeated along the construction process and may result in changes for scheduled construction tasks. The 4D macro-model and Line-of-Balance diagram are used to assess the impacts of schedule changes on the overall flow

of work in the project and, if needed, updated. The 4D micro-model is used to evaluate the spatial consequences of a rescheduling effort in the short term of the project. We applied our suggested process method to a test case, based on an industry construction project. In the next section we briefly present this application in which we focus on micro-management of required work-spaces for construction tasks.

5. Industry test case

We used 3D CAD models from the construction process of a pelletizing plant located in the city of Malmberget, Sweden, as a basis for our test case. The complexity of the project, the tight construction schedule and the fact that the plant is completely designed in 3D CAD make the project an interesting case study project (Woksepp 2005). At the time of our research the construction process was ongoing. Where possible, our work was based on actual data from the project, but most of the scheduling data and construction methods were assumed for exploratory purposes. The pelletizing plant consists of a machinery- and balling section. The machinery section consists of a large process installation that is mainly delivered by one supplier and assembled by one contractor. The balling section includes five balling stations in which steel pellets are rolled. Each balling station consists of a number of processing systems, connected by several conveyor belts. The construction process involves many different suppliers and subcontractors. Within this study a focus is made on the balling stations of the pelletizing plant.

We developed a 4D macro- and micro-model, according to our suggested process method for macro- and micro-management. The 3D CAD models were prepared in AutoCAD 2005 (Autodesk 2005) for use in combination with Line-of-Balance diagrams and for subsequent use in Ceko4D (Ceko 2006). Ceko4D is an application to link schedule data to 3D CAD components. First, locations were defined for the project. Secondly, the 3D CAD models were modeled and structured according to these locations. The third process of our suggested method involves cost estimation, but this process was not part of our case study, in which we directly moved to the fourth process; scheduling with Line-of-Balance. The Line-of-Balance diagram followed the exact same structure as the defined locations in the 3D CAD model and was developed by using Graphisoft Control (Graphisoft 2006). Construction tasks were created in the Line-of-Balance diagram for the main activities in the construction process of the pelletizing plant. The model was analyzed according to the identified

deviation types presented in Figure 2. The fifth process involved 4D modeling and 4D simulations. Schedule data was exported from Graphisoft Control and imported to Ceco4D. 3D CAD components were exported from AutoCAD as VRML files and also imported to Ceco4D where the components were linked to construction tasks. 4D CAD simulations were made after the linking process of scheduled activities to 3D CAD components was completed. The 4D macro-model that we developed suits the macro-management level of the work flow management process. The model visualizes the main activities from the master schedule and is used to plan and control the overall flow of construction work, Figure 3. The model facilitates communication of scheduling information with project participants and shows what will be built and when. The model does not include information about construction tasks' prerequisites and for this purpose we developed a 4D micro-model.

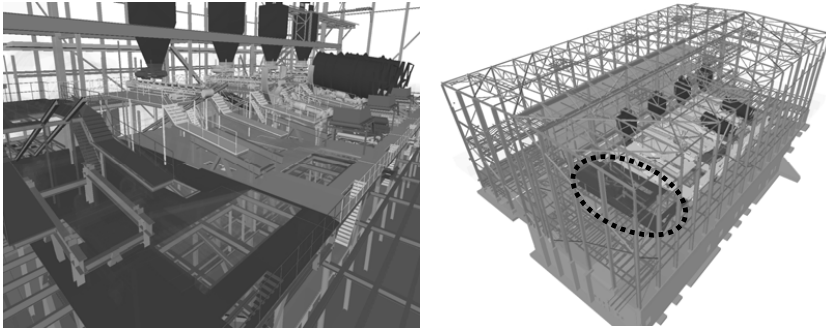

Figure 3: Two snapshots from the 4D macro-model of the case study project. 3D CAD components are grouped per balling station, marked with a circle. Dark components represent ongoing construction tasks at the time of the snapshot.

The 4D micro-model of the case study project is limited to the spatial planning of work spaces for construction crews. The 4D macro-model did not contain suitable objects for modeling and simulation of work spaces. In consultation with planners of the project we defined the required minimal size for space objects in order to plan work spaces for crews. We established a grid of semi-transparent 3D space objects that we modeled according to the grid lines used by the structural engineers in the project, resulting in space objects of seven by seven meters. Most of the project participants were familiar with the structure and naming system of the structural grid, which facilitated the understanding of the 3D space objects.

The 4D macro-model was refined into a 4D micro-model at this stage in order to represent construction tasks per construction day. Work spaces for construction workers were added in the 4D environment for a time span of three weeks by stepping through the 4D model with a one-day interval. One or more space objects were selected for every scheduled construction task (i.e. active 4D building components) on a simulated construction day, Figure 4. In this way a specification was made where construction crews would perform their work and how much space they had available for their task. The duration of this space allocation could differ from the duration of the active 4D building components, allowing for scheduling of space use for work preparations, inspection, etc. In addition to the duration of space use, a type of space use was set by which different types of activities could be distinguished as well as different construction crews. The type of a space was represented with a unique color in the 4D scene.

The work space-loaded 4D micro-model that resulted from this linking process was more detailed than the 4D macro-model and showed activities down to crew level per construction day for a period of three weeks. Figure 4 shows a snapshot of the 4D micro-model in which the work spaces are shown for four construction trades on a simulated construction day. The first trade involves steel construction followed by the second trade that installs processing units. The third trade installs conveyor belts that connect to the processing units as installed by the second trade. The fourth trade installs electrical installations and wiring. The first trade provides work space area for the successive trades. The construction tasks by trade two, three and four are highly concurrent and performed on multiple locations in a limited construction space inside the pelletizing plant.

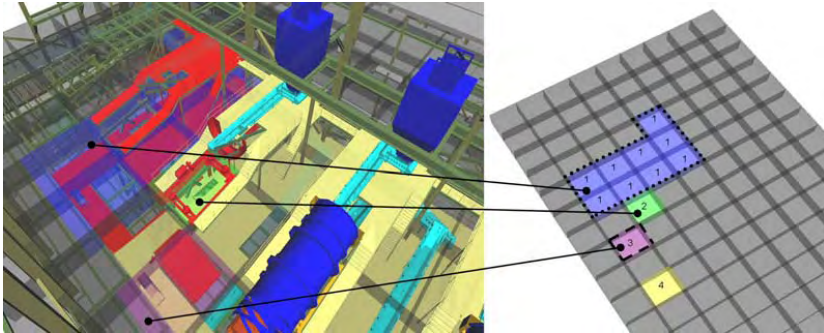

Figure 4: (Left) A snapshot from the 4D micro-model including building components and spaces. (Right) The same 4D micro-model limited to visualizing work spaces. 1 - Spaces used by the steel construction crew. 2 - Spaces used by the second trade that installs processing units. 3 - Spaces are used by third trade that installs conveyor belts. 4 - Spaces used by the fourth trade that installs electrical installations and wiring.

Figure 5 presents six snapshots of the 4D micro-model taken with a two- to three-day interval for construction work scheduled in January 2006. Figure 5 shows how the construction trades move through the pelletizing plant while working at different locations on almost every other construction day. This implies that the spatial conditions for the performance of construction tasks are different inside the plant during the construction process. Figure 5 helps planners to understand the flow of crews through the pelletizing plant. Planners are also provided with an overview of the work space consumption that is required for the execution of construction tasks. In addition to an overview of the work space that is used, planners can identify work space that is available and in this way identify scheduling opportunities.

Figure 5 suggest that the second and third trades are dynamic trades during the specific simulated construction days for which the snapshots from the 4D micro-model are taken. At certain days the trades use multiple locations for their work. On 11 and 20 January the location usage can force the second and third trade to cross each other's work spaces. Crossing other trades' work spaces or working adjacent other trades can negatively influence the productivity of the trades and can lead to hazardous situations for construction

crews (Akbas 2004). Planners can evaluate and manage these situations in advance by using this methodology and set of tools.

A number of planning issues was discovered during the 4D micro-modeling process. For example, situations were identified in which two or more trades had to share the same work space. These situations were filtered out of the production planning by rescheduling the order of installation of building components. The 4D macro-model was used to evaluate the constructability of this new process design and to assess the impact on the overall flow of construction work. The 4D micro-model provided with further insights in the work space usage and flow of crews through the pelletizing plant. The two 4D models provided two levels of abstraction of construction schedule information that were useful for different types of construction planning optimization.

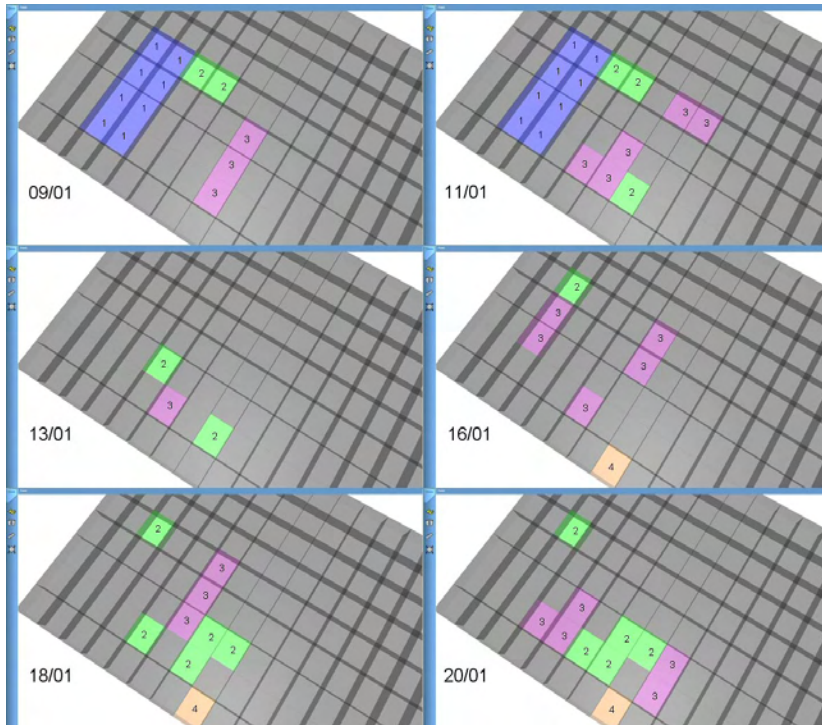

Figure 5: Six snapshots of the 4D micro-model taken with a two- to three-day interval. 1 - Spaces used by the steel construction crew. 2 - Spaces used by the second trade that installs processing units. 3 - Spaces are used by third trade that installs conveyor belts. 4 - Spaces used by the fourth trade that installs electrical installations and wiring.

6. Discussion and further research

The integration of location-based scheduling techniques and 4D CAD provides a promising method to plan and control construction tasks from a work flow perspective. We presented a process method for combined use of both techniques, and applied this method in a test study. The construction process of the case study is mostly hypothetical, but shows a type of process design and reasoning that does not occur in today's construction projects. Reasoning, such as analyzing work space usage and re-routing trades, is done in actual production where there is limited opportunity to change construction execution

strategies. The spatial dimension of the preconditions for the sound execution of construction tasks is not taken into account. As a result, the risk increases for task execution under sub-optimal conditions. This situation can negatively affect productivity and safety of construction crews, and can have a negative impact on the overall flow of work in a project.

The proposed process method in this article uses the Line-of-Balance technique in combination with 4D macro-models for work flow management. The Line-of-Balance diagram allows planners to quickly gain insight in the flow of resources through locations in projects. The 4D macro-model provides a valuable supplement to the Line-of-Balance diagrams. 4D models address a number of shortcomings from the Line-of-Balance method, such as the spatial configuration of construction tasks and definition of locations in a project. On a micro-level of work flow management the method uses 4D micro-models to spatially plan construction tasks' prerequisites. Current methods for micro-management (Ballard 2003; Kenley 2004) do not explicitly consider the spatial dimension of these prerequisites. We showed the spatial planning of one (i.e. space used by crews) of the seven identified preconditions for construction tasks by using 4D models. We believe that other preconditions, such as equipment and material, require a similar spatial planning approach. In addition, the relation between different types of space use should be taken into account (Akinci 2002), as certain types of space use provide conditions for the allocation of spaces for other types of use.

In the process of manually modeling work spaces we made certain assumptions about how to allocate work spaces to construction tasks. The process of modeling and allocating work spaces could be automated with appropriate mechanisms. The 4D models from the case study were mainly used for graphical analyses. Further research is required to study what quantitative data contained in 4D CAD models can be extracted and used for analyses in the planning and control process for work flow. One extension could be the management of the supply chain to and on the building site.

The macro- and micro-management method that we suggest is partially based on techniques and principles from lean construction research. The Last Planner method, which is a prominent tool for lean delivery of construction projects, was adopted as a basis for the 4D-based micro-management method. We suggest additional studies of how principles from lean construction can be combined with virtual design and construction methods, such as 4D modeling, in order to reinforce both areas of research and application.

References

- Akbas, R. (2004). "Geometry-based modeling and simulation of construction processes," PhD Thesis, Department of Civil and Environmental EngineeringStanford University, Stanford, CA, 150 pp.
- Akinci, B., Fischer, M., and Kunz, J. (2002). "Automated Generation of Work Spaces Required by Construction Activities." *Journal of Construction Engineering and Management*, 128(4), 10.
- Autodesk, Inc. (2005). "AutoCAD - Architectural Desktop 2005." San Rafael, USA.
- Ballard, G., Howell, G. (1998). "Shielding Production: Essential Step in Production Control." *Journal of Construction Engineering and Management*, 124(4), 279-288.
- Ballard, G., Howell, G. (2003) "An Update on Last Planner." In J. C. Martinez, Formoso, C.T. (eds) *11th International Group for Lean Construction Conference*, Virginia Tech, Blacksburg, Virginia, USA,
- Ceco. (2006). "Ceco4D - Model Publisher & 4D Viewer." Stockholm, Sweden.
- Fischer, M., and Haddad, Z. (2004) "A pull-driven project planning and control philosophy and approach." In P. Brandon, Li, H., Shaffii, N., Shen, Q. (eds) *INCITE 2004 - International Conference on Information Technology in Design and Construction*, Langkawi, Malaysia, 23-32.
- Graphisoft, Inc. (2006). "Virtual Construction - Graphisoft ArchiCAD, Constructor, Estimator, Control and 5D Presenter." www.graphisoft.com.
- Hopp, W. and Spearman, M. (1996). *Factory Physics: Foundations of Manufacturing Management*, Irwin/McGraw-Hill, Boston. 668 pp.
- Huber, B., Reiser, P. (2003) "The Marriage of CPM and Lean Construction." In J. C. Martinez, Formoso, C.T. (eds) *11th International Group for Lean Construction Conference*, Virginia Tech, Blacksburg, Virginia, USA

-
- Jongeling, R., Kim, J., Mourgues, C., Fischer, M., Olofsson T. (2005) "Quantitative Analysis Using 4D Models - An Explorative Study." In C. Park (eds) *First International Conference on Construction Engineering and Management*, Seoul, Korea, 830-835.
- Jongeling, R., Olofsson T. (2006). "A method for planning of work-flow by combined use of location-based scheduling and 4D CAD." *Automation in Construction* (article in press).
- Josephson, P-E., Saukkoriipi, L. (2005). "Slöseri i byggprojekt - behov av förändrat synsätt (Waste in construction projects - the need for a different view)." Göteborg, Sweden.
- Kankainen, J., Seppänen, O. (2003) "A Line-of-Balance based schedule planning and control system." In J. C. Martinez, Formoso, C.T. (eds) *11th International Group for Lean Construction Conference*, Virginia Tech, Blacksburg, Virginia, USA,
- Kenley, R. (2004) "Project micromanagement: practical site planning and management of work flow." In S. Bertelsen, Formoso, C.T. (eds) *IGLC-12, 12th Conference of the International Group for Lean Construction*, Helsingor, Denmark, 194-205.
- Koo, B., and Fischer, M. (2000). "Feasibility Study of 4D CAD in Commercial Construction." *Journal of Construction Engineering and Management*, 126(4), 251-260.
- Koskela, L. (1999) "Management of Production in Construction: A Theoretical View." In I. D. Tommelein, Ballard, G. (eds) *IGLC 7: Proceedings of the Annual Conference of the International Group for Lean Construction*, University of California, Berkeley, CA, USA, 241-252.
- McKinney, K., and Fischer, M. (1998). "Generating, evaluating and visualizing construction with 4D-CAD." *Automation in Construction*, 7(1998), 433-447.
- O'Brien, J. J. (1975). "VPM Scheduling for High-Rise Buildings." *ASCE J Constr Div*, 101(4), 895-905.
- Ronen, B. (1992). "The Complete Kit Concept." *International Journal of Production Research*, 30(10), 2457-2466.

- Seppänen, O., Kankainen, J. (2004) "Empirical research on deviations in production and current state of project control." In S. Bertelsen, Formoso, C.T. (eds) *IGLC-12, 12th Conference of the International Group for Lean Construction*, Helsingor, Denmark, 206-219.
- Stradal, O., and Cacha, J. (1982). "Time Space Scheduling Method." *ASCE J Constr Div*, 108(CO3), 445-457.
- Woksepp, S., Jongeling, R., and Olofsson, T. (2005) "Applying Virtual Reality and 4D CAD models in the scheduling process of a large pelletizing plant." In N. Dawood (eds) *CONVR - Conference on Construction Applications of Virtual Reality*, Durham, England

DOCTORAL AND LICENTIATE THESES

The following Doctoral and Licentiate theses have been written by researchers at the Division of Structural Engineering, Luleå University of Technology.

Doctoral Theses

Ulf Arne Girhammar (1980): *Dynamic Fail-Safe Behaviour of Steel Structures*.
Doctoral Thesis 1980:060D. 309 pp.

Kent Gylltoft (1983): *Fracture Mechanics Models for Fatigue in concrete Structures*.
Doctoral Thesis 1983:25D. 210 pp.

Thomas Olofsson (1985): *Mathematical Modelling of Jointed Rock Masses*. In
collaboration with the Division of Rock Mechanics. Doctoral Thesis 1985:42D,
143 pp.

Lennart Fransson (1988): *Thermal ice pressure on structures in ice covers*. Doctoral
Thesis 1988:67D. 161 pp.

Mats Emborg (1989): *Thermal stresses in concrete structures at early ages*. Doctoral
Thesis 1989:73D. 285 pp.

Lars Stehn (1993): *Tensile fracture of ice. Test methods and fracture mechanics
analysis*. Doctoral Thesis 1993:129D, September 1993, 136 pp.

Björn Täljsten (1994): *Plate Bonding. Strengthening of existing concrete structures
with epoxy bonded plates of steel or fibre reinforced plastics*. Doctoral Thesis
1994:152D, August 1994, 283 pp.

Jan-Erik Jonasson (1994): *Modelling of temperature, moisture and stresses in young
concrete*. Doctoral Thesis 1994:153D, August 1994, 227 pp.

Ulf Ohlsson (1995): *Fracture Mechanics Analysis of Concrete Structures*. Doctoral
Thesis 1995:179D, December 1995, 98 pp.

-
- Keivan Noghabai (1998): *Effect of Tension Softening on the Performance of Concrete Structures*. Doctoral Thesis 1998:21, August 1998, 150 pp.
- Gustaf Westman (1999): *Concrete Creep and Thermal Stresses. New creep models and their effects on stress development*. Doctoral Thesis 1999:10, May 1999, 301 pp.
- Henrik Gabrielsson (1999): *Ductility in High Performance Concrete Structures. An experimental investigation and a theoretical study of prestressed hollow core slabs and prestressed cylindrical pole elements*. Doctoral Thesis 1999:15, May 1999, 283 pp.
- Groth, Patrik (2000): *Fibre Reinforced Concrete - Fracture Mechanics Methods Applied on Self-Compacting Concrete and Energetically Modified Binders*. Doctoral Thesis 2000:04, January 2000, 214 pp.
- Hans Hedlund (2000): *Hardening concrete. Measurements and evaluation of non-elastic deformation and associated restraint stresses*. Doctoral Thesis 2000:25, December 2000, 394 pp ISBN 91-89580-00-1.
- Anders Carolin (2003): *Carbon Fibre Reinforced Polymers for Strengthening of Structural Members*. Doctoral Thesis 2003:18, June 2003, ISBN 91-89580-04-4. 190 pp.
- Martin Nilsson (2003): *Restraint Factors and Partial Coefficients for Crack Risk Analyses of Early Age Concrete Structures*. Doctoral Thesis 2003:19, June 2003, ISBN: 91-89580-05-2, 170 pp.
- Mårten Larson (2003): *Thermal Crack Estimation in Early Age Concrete – Models and Methods for Practical Application*. Doctoral Thesis 2003:20, June 2003, ISBN 91-86580-06-0. 190 pp.
- Erik Nordström (2005): *Durability of Sprayed Concrete. Steel fibre corrosion in cracks*. Doctoral Thesis 2005:02, January 2005, ISSN 1402-1544. 151 pp.

Licentiate Theses

- Lennart Fransson (1984): *Bärförmåga hos ett flytande istäcke. Beräkningsmodeller och experimentella studier av naturlig is och av is förstärkt med armering.* Licentiate Thesis 1984:012L.
- Mats Emborg (1985): *Temperature stresses in massive concrete structures. Viscoelastic models and laboratory tests.* Licentiate Thesis 1985:011L, May 1985, rev November 1985, 163 pp.
- Christer Hjalmarsson (1987): *Effektbehov i bostadshus. Experimentell bestämning av effektbehov i små- och flerbostadshus.* Licentiate Thesis 1987:009L, October 1987, 72 p.
- Björn Täljsten (1990): *Förstärkning av betongkonstruktioner genom pålimning av stålplåtar.* Licentiate Thesis 1990:06L, May 1990.
- Ulf Ohlsson (1990): *Fracture Mechanics Studies of Concrete Structures.* Licentiate Thesis 1990:07L, May 1990, 8 + 12 + 18 + 7 + 21 pp.
- Lars Stehn (1991): *Fracture Toughness of sea ice. Development of a test system based on chevron notched specimens.* Licentiate Thesis 1991:11L, September 1990, 88 pp.
- Per Anders Daerga (1992): *Some experimental fracture mechanics studies in mode I of concrete and wood.* Licentiate Thesis 1992:12L, 1ed April 1992, 2ed June 1992, 81 pp.
- Henrik Gabrielsson (1993): *Shear capacity of beams of reinforced high performance concrete.* Licentiate Thesis 1993:21L, May 1993, 109 pp. 18 June.
- Keivan Noghabai (1995): *Splitting of concrete in the anchoring zone of deformed bars. A fracture mechanics approach to bond.* Licentiate Thesis 1995:26L, May 1995, 123 pp.
- Gustaf Westman (1995): *Thermal cracking in high performance concrete. Viscoelastic models and laboratory tests.* Licentiate Thesis 1995:27L, May 1995, 125 pp.
- Katarina Ekerfors (1995): *Mognadsutveckling i ung betong. Temperaturkänslighet, hållfasthet och värmeutveckling.* Licentiate Thesis 1995:34L, October 1995, 137 pp.
- Patrik Groth (1996): *Cracking in concrete. Crack prevention with air-cooling and crack distribution with steel fibre reinforcement.* Licentiate Thesis 1996:37L, October 1996, 128 pp.
- Hans Hedlund (1996): *Stresses in High Performance Concrete due to Temperature and Moisture Variations at Early Ages.* Licentiate Thesis 1996:38L, October 1996, 240 pp.

-
- Mårten Larson (2000): *Estimation of Crack Risk in Early Age Concrete. Simplified methods for practical use*. Licentiate Thesis 2000:10, April 2000, 170 pp.
- Bernander, Stig (2000): *Progressive Landslides in Long Natural Slopes. Formation, potential extension and configuration of finished slides in strain-softening soils*. Licentiate Thesis 2000:16, May 2000, 137 pp.
- Martin Nilsson (2000): *Thermal Cracking of young concrete. Partial coefficients, restraint effects and influences of casting joints*. Licentiate Thesis 2000:27, October 2000, ISSN 1402-1757, 267 pp.
- Erik Nordström (2000): *Steel Fibre Corrosion in Cracks. Durability of sprayed concrete*. Licentiate Thesis 2000:49, December 2000, 103 pp.
- Anders Carolin (2001): *Strengthening of concrete structures with CFRP – Shear strengthening and full-scale applications*. Licentiate thesis, June 2001, ISBN 91-89580-01-X 2001:01 120 pp.
- Håkan Thun (2001): *Evaluation of concrete structures. Strength development and fatigue capacity*. Licentiate thesis 2001:25. June 2001, ISBN 91-89580-08-2, 164 pp.
- Patrice Godonue (2002): *Preliminary Design and Analysis of Pedestrian FRP Bridge Deck*. Licentiate thesis 2002:18, 203 pp.
- Jonas Carlswärd (2002): *Steel fibre reinforced concrete toppings exposed to shrinkage and temperature deformations*. Licentiate thesis 2002:33, August 2002, 46 + 66 pp.
- Sofia Utsi (2003): *Self-Compacting Concrete - Properties of fresh and hardening concrete for civil engineering applications* Licentiate thesis 2003:19, June 2003, 36 + 149 pp.
- Anders Rönneblad (2003): *Product Models for Concrete Structures - Standards, Applications and Implementations*. Licentiate thesis 2003:22, June 2003, 29 + 75 pp.
- Håkan Nordin (2003): *Strengthening of Concrete Structures with Pre-Stressed CFRP*. Licentiate Thesis 2003:25, June 2003, 57 + 68 pp.
- Arto Puurula (2004): *Assessment of Prestressed Concrete Bridges Loaded in Combined Shear, Torsion and Bending*, Licentiate Thesis 2004:43, November 2004, 102 + 110 pp.
- Arvid Hejll (2004): *Structural Health Monitoring of Bridges. Monitor, Assess and Retrofit*. Licentiate Thesis 2004:46, November 2004, 43 + 85 pp.
- Ola Enochsson (2005): *CFRP Strengthening of Concrete Slabs, with and without Openings. Experiment, Analysis, Design and Field Application*. Licentiate Thesis 2005:87, November 2005, 154 pp.

